

ROBE

ROBIN iBeam 350™

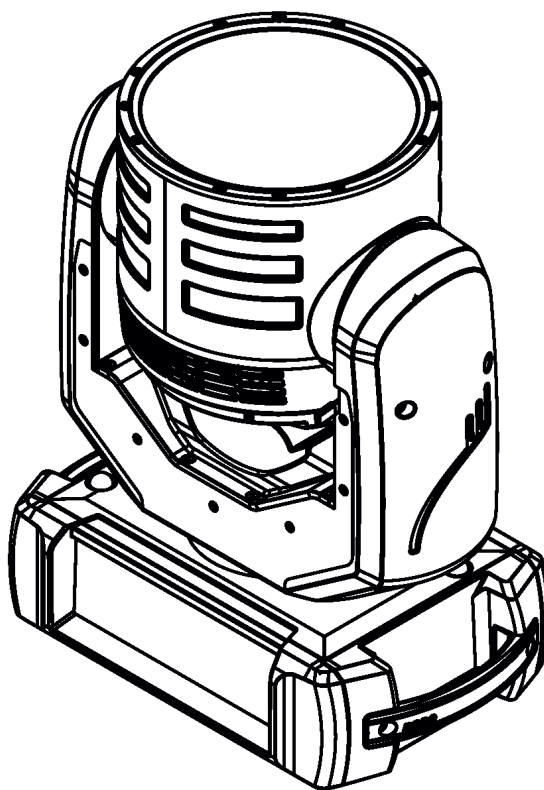

ROBE
Innovative
Technology

QR code for user manual



USER MANUAL

ROBE® lighting s.r.o. • Czech Republic • www.robe.cz

Version 1.3

Robin iBeam 350

Table of contents

1. Safety instructions	3
2. Operating determination	4
3. Fixture exterior view	6
4. Installation	7
4.1 Connection to the mains	7
4.2 Rigging the fixture	10
4.3 DMX-512 connection.....	14
4.4 Ethernet connection	15
4.5 Wireless DMX operation	17
5. Checking the IP65 integrity of the fixture	18
6. Operating the fixture at ambient temperatures below 0°C	20
7. Standby mode	21
8. Remotely controllable functions	22
9. Control menu map	22
10. Control menu	26
10.1 Tab "Address"	29
10.2 Tab "Information"	30
10.3 Tab "Personality"	32
10.4 Tab "Manual Control"	34
10.5 Tab "Stand-alone"	34
10.6 Tab "Service"	35
11. RDM	38
12. NFC	39
13. Error and information messages	40
14. Cleaning	40
15. Maintenance	40
15.1 Torques for watertight covers	43
15.2 Torques of Pan/Tilt motors screws	47
15.3 Checking and replacing the silica gel desiccants	48
16. Robe Ethernet Access Portal (REAP)	51
17. Technical Specifications	59
18. ChangeLog	62

**FOR YOUR OWN SAFETY, PLEASE READ THIS USER MANUAL CAREFULLY
BEFORE YOU INITIAL START - UP**

This device has left our premises in absolutely perfect condition. In order to maintain this condition and to ensure a safe operation, it is absolutely necessary for the user to follow the safety instructions and warnings in this manual.

The manufacturer will not accept liability for any resulting damages caused by the non-observance of this manual or any unauthorized modification to the device.

Please consider that damages caused by manual modifications to the device are not subject to warranty.

The Robin iBeam 350 was designed for outdoor use and it is intended for professional application only. It is not for household use.

1. Safety instructions

CAUTION!

Disconnect the fixture from mains before removing any cover of the fixture. With a high voltage you can suffer a dangerous electric shock when touching alive wires and electrical parts under covers!

Make sure that the available voltage is not higher than stated on the rear panel of the fixture. This fixture should be operated only from the type of power source indicated on the marking label. If you are not sure of the type of power supplied, consult your authorized distributor or local power company.

Always disconnect the fixture from AC power before cleaning or servicing any part of the fixture.

The power plug has to be accessible after installing the fixture. Do not overload wall outlets and extension cords as this can result in fire or electric shock.

Do not allow anything to rest on the power cord. Do not locate this fixture where the cord may be damaged by persons walking on it.

Make sure that the power cord is never crimped or damaged by sharp edges. Check the fixture and the power cord from time to time.

Refer servicing to qualified service personnel.

This fixture falls under protection class I. Therefore this fixture has to be connected to a mains socket outlet with a protective earthing connection.

Do not connect this fixture to a dimmer pack.

During the initial start-up some smoke or smell may arise. This is a normal process and does not necessarily mean that the device is defective.

The housing of the fixture becomes hot during its operation.

For replacement use fuse and battery of same type and rating only.

Warning! Risk Group 2 LED product according to EN 62471.



***LED light emission. Risk of eye injury.
Do not look straight at the fixture's LED source during operation. The intense light beam may damage your eyes. Sensitive persons may suffer an epileptic shock.
Provide advance notice that strobe lighting is in use.***

***Do not view the light output with optical instruments or any device that may concentrate the beam.
The light source contains blue LEDs.***

2. Operating determination

WARNING! This unit does not contain an ON/OFF switch. Always disconnect the power input cable from mains to completely remove power from unit when not in use or before cleaning or servicing the unit.

Avoid brute force when installing or operating the device.

Never lift the fixture by holding it at the fixture head as the mechanics may be damaged. Always hold the fixture at the transport handles.

When choosing the installation spot, please make sure that the device is not exposed to extreme heat or dust.

Make sure that the area below the installation place is blocked when rigging, derigging or servicing the fixture.

Always secure the fixture with an appropriate safety wire.

Only operate the fixture after having checked that the housing is firmly closed and all screws are tightly fastened.

Do not block the front cover glass with any object when the fixture is under operation.

The fixture becomes very hot during operation. Allow the fixture to cool approximately 20 minutes prior to manipulate with it.

To avoid damage of an internal optical system of the fixture, never let the sunlight (or other light source) lights directly to the lens array, even when the fixture is not working

Operate the device only after having familiarized with its functions. Do not permit operation by persons not qualified for operating the device.

The fixture housing never must be covered with cloth or other materials during its operation. Do not block fans or fans ventilation slots with any object. Fans and ventilation slots must remain clean.

Please consider that unauthorized modifications on the device are forbidden due to safety reasons!

Potential foggy front lens array does not influence function of the fixture and does not subject to complaint.

Potential colour non-uniformity of the front lens array may occur, it does not influence colour output from the fixture and is not considered a fault.

Please use only an original ROBE packaging (paper box, loader case or foam shell) for transporting the device, otherwise potential damage of the device during its transport will not subject to warranty.

***The fixture must not come into contact with sea water (salt water).
Damages or corrosion issues resulting from salt water will void the manufactures warranty and will not be subject to any warranty claims or repairs.***

The product (covers and cables) must not be exposed to a high frequency electromagnetic field higher than 3V/m.

Immunity of the equipment is designed according to the standard EN 55035 Electromagnetic compatibility of multimedia equipment - Immunity requirements

Emission of the equipment complies with the standard EN55032 Electromagnetic compatibility of multimedia equipment – Emission Requirements according to class B.

Contains FCC ID: 2A6PL-DMXRDMRW001

Contains IC: 29573-DMXRDMRW001

This device complies with part 15 of the FCC Rules. Operation is subject to the following two conditions: (1) This device may not cause harmful interference, and (2) this device must accept any interference received, including interference that may cause undesired operation.

Changes or modifications not expressly approved by the party responsible for compliance could void the user's authority to operate the equipment.

The [Device] wireless operation is safe and complies to RF Exposure requirements

This equipment has been tested and found to comply with the limits for a Class B digital device, pursuant to part 15 of the FCC Rules. These limits are designed to provide reasonable protection against harmful interference in a residential installation. This equipment generates, uses and can radiate radio frequency energy and, if not installed and used in accordance with the instructions, may cause harmful interference to radio communications. However, there is no guarantee that interference will not occur in a particular installation. If this equipment does cause harmful interference to radio or television reception, which can be determined by turning the equipment off and on, the user is encouraged to try to correct the interference by one or more of the following measures:

- Reorient or relocate the receiving antenna.
- Increase the separation between the equipment and receiver.
- Connect the equipment into an outlet on a circuit different from that to which the receiver is connected.
- Consult the dealer or an experienced radio/TV technician for help.

3. Fixture exterior view

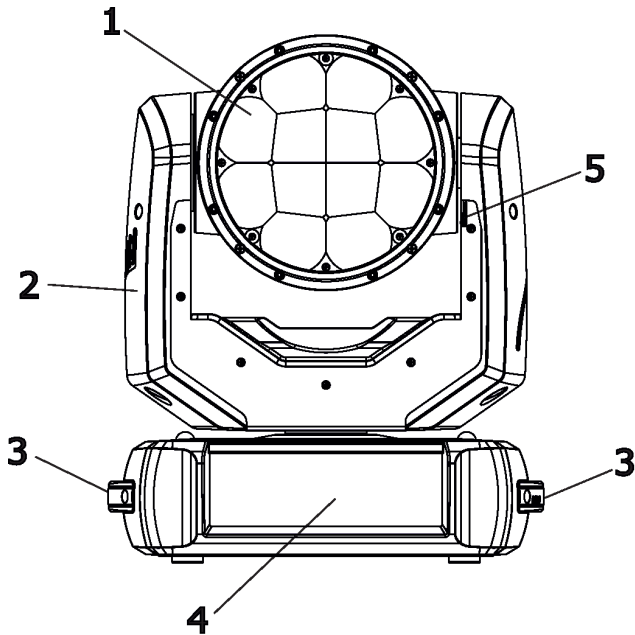

- 1 - Lens array
- 2 - Yoke
- 3 - Handle
- 4 - Control panel with display
- 5 - Tilt lock
- 6 - Cover of Battery holder and fuse holder
- 7 - Ethernet OUT (IP65 RJ45 connector)
- 8 - Ethernet IN (IP65 RJ45 connector)
- 9 - DMX IN (IP65 Locking 5-pin XLR connector)
- 10 - DMX OUT (IP65 Locking 5-pin XLR connector)
- 11- Power (IP65 power connector)

Robin iBeam 350 POI

- 4 - Anti-vandal cover of control panel
- 6 - Cover of Battery holder and fuse holder
- 8 - DMX OUT (cable + IP65 Locking 5-pin XLR connector)
- 9 - DMX IN (cable + IP65 Locking 5-pin XLR connector)
- 11- Power (open ended cable)

Robin iBeam 350 POI

(POI = Permanent Outdoor Installation)

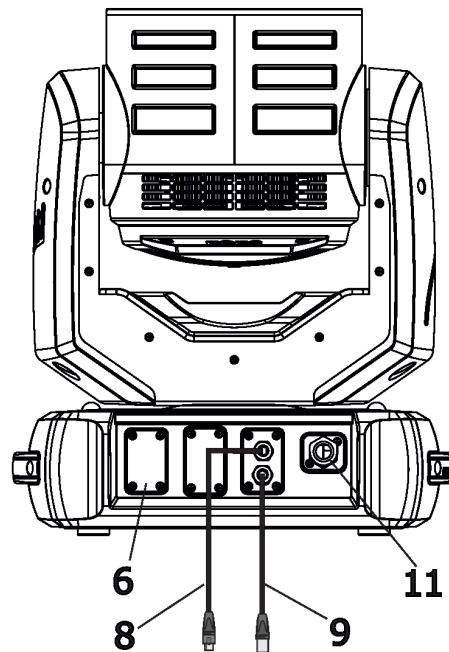
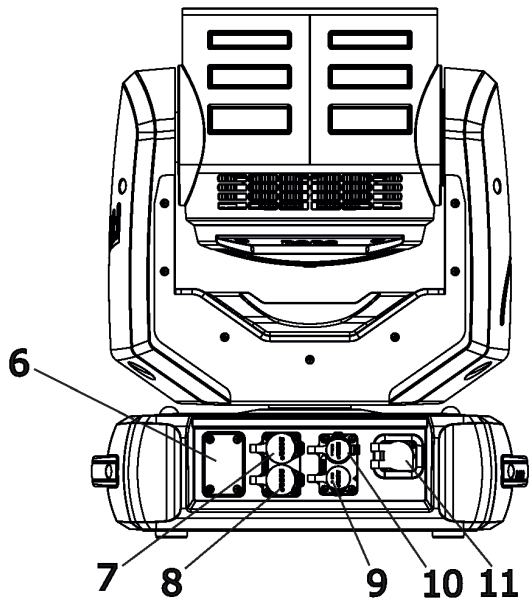

The head has to be locked for transportation - the tilt lock latch (5) has to be in the locked position. To unlock the head, move this latch to unlock position before operating the fixture.

The ENTER/DISPLAY ON button also serves for switching the display on when the fixture is disconnected from the mains.

4. Installation



Fixtures must be installed by a qualified electrician in accordance with all national and local electrical and construction codes and regulations.

The Robin iBeam 350's panel connectors are dust and water protected according to IP 65 by mating with related cable connectors. They cannot stay disconnected outdoor.

All unused panel connectors have to be sealed by the rubber caps.

Visually check panel connectors on accidental water leaks before connecting related cable connectors.

If some water will appear in panel connectors, do not connect cable connectors, especially power!

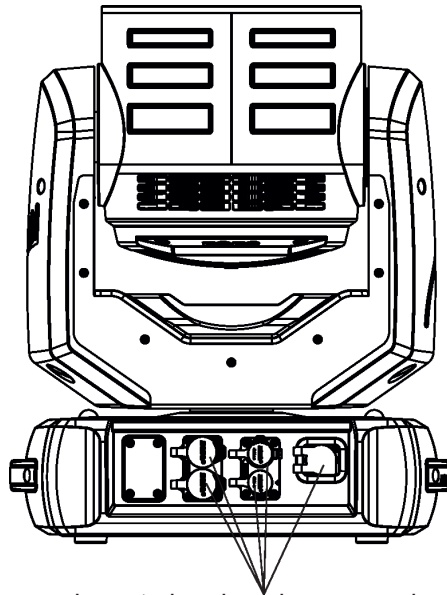

The rubber caps have to be placed on unused connectors.

4.1 Connection to the mains

**For protection from electric shock, the fixture must be earthed!
The fixture has to be connected to an electric outlet which is equipped with a residual-current device (residual-current circuit breaker)!**

Wiring and connection work must be carried out by a qualified electrician.

The Robin iBeam 350 is equipped with auto-switching power supply that automatically adjusts to any 50-60Hz AC power source from 100-240 Volts.

Mains cable powerCON TRUE1 In/open ended is enclosed to the fixture. We recommend to install cord end-sleeves 1.5 x 8 (cross section in mm² x length in mm) on the cords of the mains cable. If you need to install a power plug on the mains cable to allow connection to power outlets, install a grounding-type (earthed) plug, following the plug manufacturer's instructions. If you have any doubts about proper installation, consult a qualified electrician. Connection to mains has to keep IP 65 protection rating.

Core (EU)	Core (US)	Connection	Plug Terminal Marking
Brown	Black	Live	L
Light blue	White	Neutral	N
Yellow/Green	Green	Earth	

This device falls under class one and must be earthed (grounded)!

Ensure all connections and the power plug on the cable are properly sealed.

To apply power, first check that the head tilt lock is released.

POI version of the fixture - front side of the base

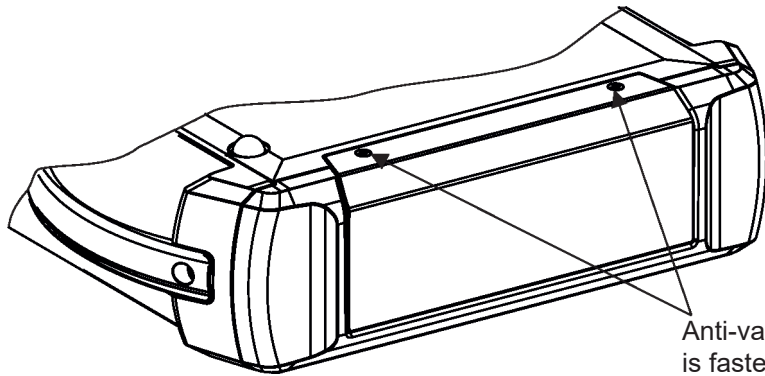

Anti-vandal cover of the control panel is fasten to the base by means of two screws

POI version of the fixture - rear side of the base (variant 1)

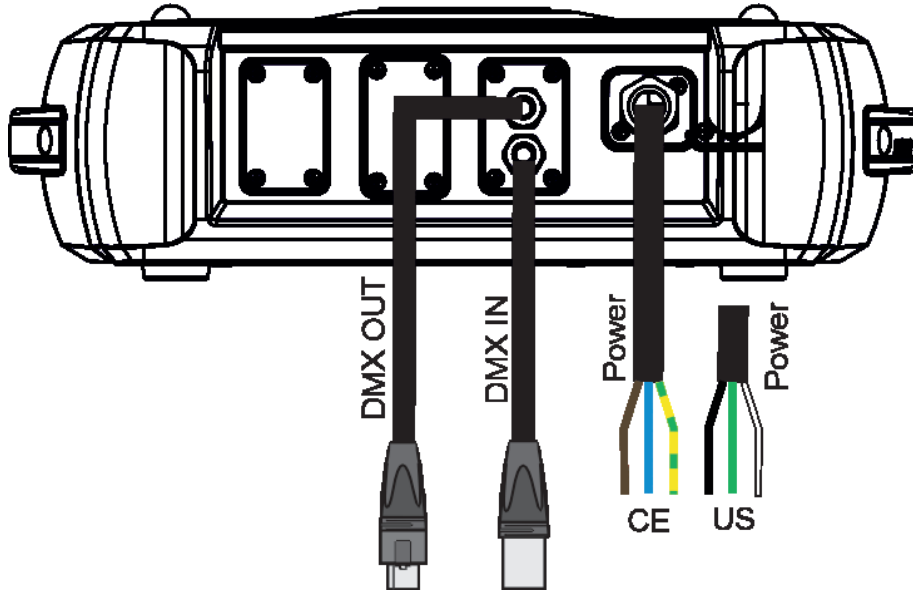

***Fixtures cable connectors are dust and water protected according to IP 65 by mating with related cable connectors. They cannot stay disconnected outdoor.
 All unused cable connectors have to be sealed by the rubber cap.
 Power cable cannot stay disconnected outdoor.
 Visually check cable connectors on accidental water leaks before connecting related cable connectors.
 If some water will appear in cable connectors, do not connect cable connectors.***

Connection to mains has to keep IP 65 protection rating.

Power (CE)

Wire	Function
Brown	Live
Blue	Neutral
Yellow/Green	⊕ (earth)

Power (US)

Wire	Function
Black	Live
White	Neutral
Green	⊕ (earth)

POI version of the fixture - rear side of the base (variant 2)

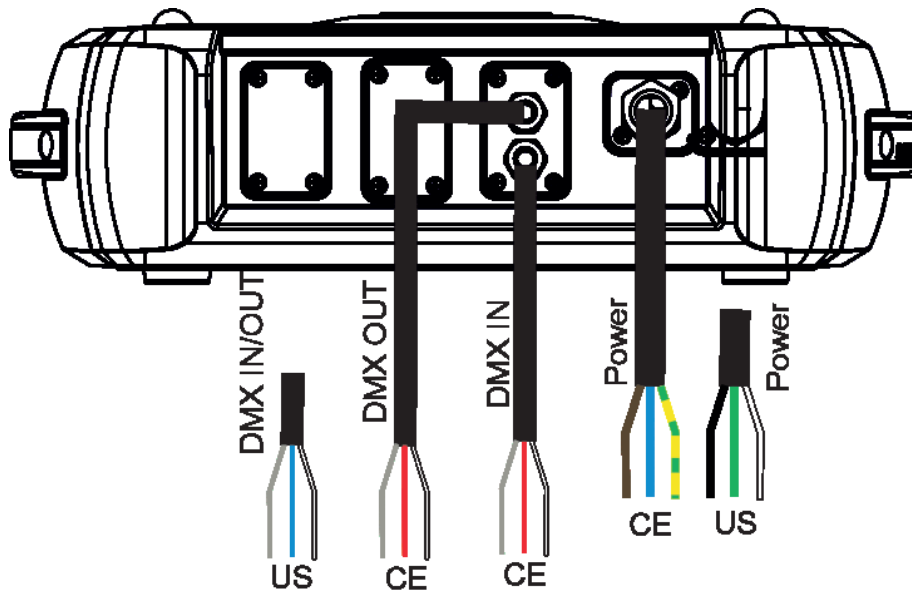

***Power and DMX cables cannot stay disconnected outdoor.
Connection to mains and connection to DMX have to keep IP 65 protection rating.***

Power (CE)

Wire	Function
Brown	Live
Blue	Neutral
Yellow/Green	⊕ (earth)

Power (US)

Wire	Function
Black	Live
White	Neutral
Green	⊕ (earth)

DMX (CE)

Wire	Function
Red	Data +
White	Data -
Shielding	Data ground

DMX (US)

Wire	Function
Blue	Data +
White	Data -
Shielding	Data ground

4.2 Rigging the fixture

A structure intended for installation of the fixture (s) must safely hold weight of the fixture(s) placed on it. The structure has to be certificated to the purpose.

The fixture (fixtures) must be installed in accordance with national and local electrical and construction codes and regulations.

For overhead installation, the fixture must be always secured with a safety wire.

When rigging, derigging or servicing the fixture staying in the area below the installation place, on bridges, under high working places and other endangered areas is forbidden.

Allow the fixture to cool for ten minutes before handling.

Fixture should be installed in areas outside walking paths, seating areas, or away from areas where unauthorized personnel might reach the fixture by hand.

IMPORTANT! OVERHEAD RIGGING REQUIRES EXTENSIVE EXPERIENCE, including calculating working load limits, installation material being used, and periodic safety inspection of all installation material and the projector. If you lack these qualifications, do not attempt the installation yourself, but use a help of professional companies.

CAUTION: Fixtures may cause severe injuries when crashing down! If you have doubts concerning the safety of a possible installation, do not install the fixture!

The fixture has to be installed out of the reach of public.

The fixture must never be fixed swinging freely on the truss.

Danger of fire !
When installing the device, make sure there is no highly inflammable material (decoration articles, etc.) in a distance of min. 0.5 m.

CAUTION!
Use 2 appropriate clamps to rig the fixture on the truss.
Follow the instructions mentioned at the bottom of the base.
Make sure that the device is fixed properly! Ensure that the structure (truss) to which you are attaching the fixtures is secure.

For securing the fixture to the truss, install a safety wire which can hold at least 10 times the weight of the fixture.

Truss installation

1. Bolt Clamps (4) to the Omega adaptors (1) with M12 bolts and lock nuts through the hole in the Omega adaptor.
2. Fasten the Omega adaptors on the bottom of the base by means of the quick-lock fasteners (2) and tighten them fully clockwise.
3. Install the fixture on the truss.
4. Pull a safety wire (3) through the carrying handle and the truss (6) as shown on the picture below in a suitable position so that the maximum fall of the fixture will be 20 cm. Fasten a snap hook in the attachment point (5). Use only the safety wire with a snap hooks with screw lock gates.

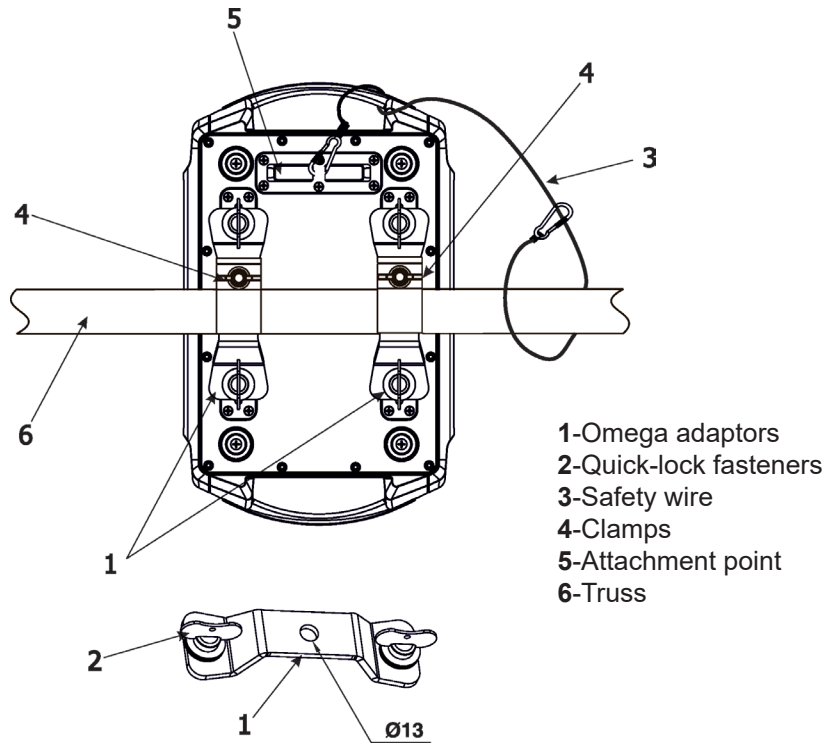

Note:

Surface corrosion of the Omega adaptors may occur, especially if this fixture has been used outdoors. Surface corrosion will not affect the safety of the Omega adaptors. Omega adaptors corrosion is not covered by the warranty.

Available positions of Omega adaptors

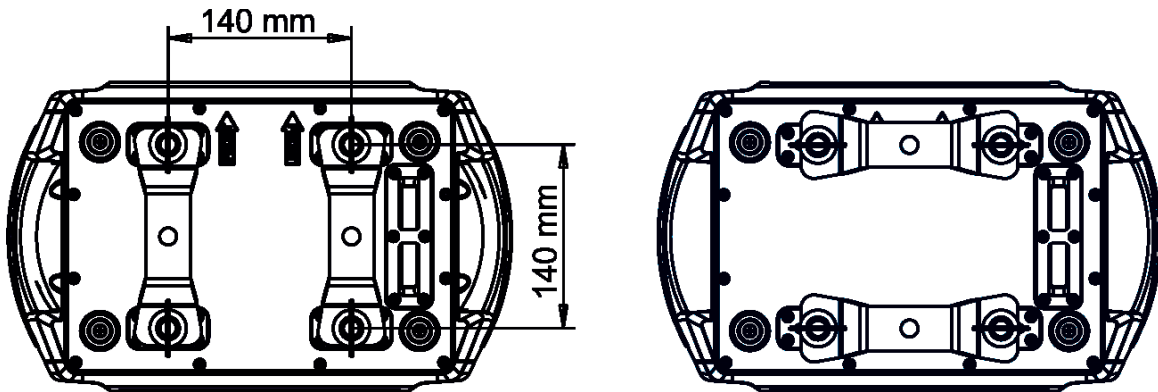

Allowed installation positions of the Robin iBeam 350

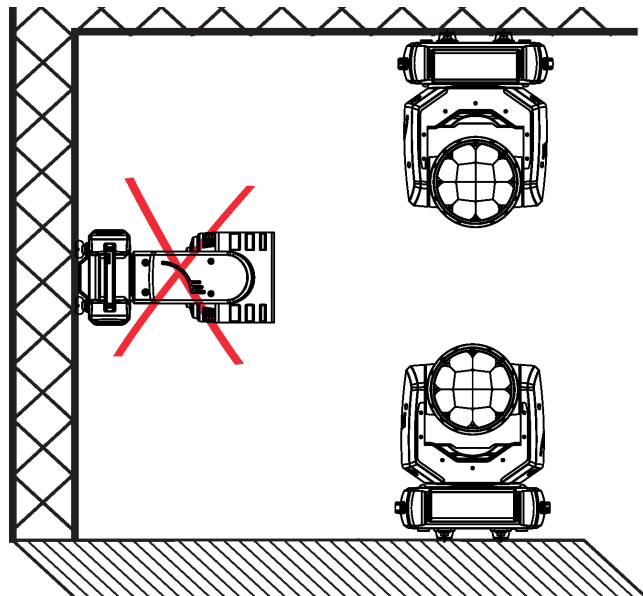

Note for open-air installation: if the fixture stands on the ground, min. distance of 4" (10cm) between the fixture base and the ground has to be kept.

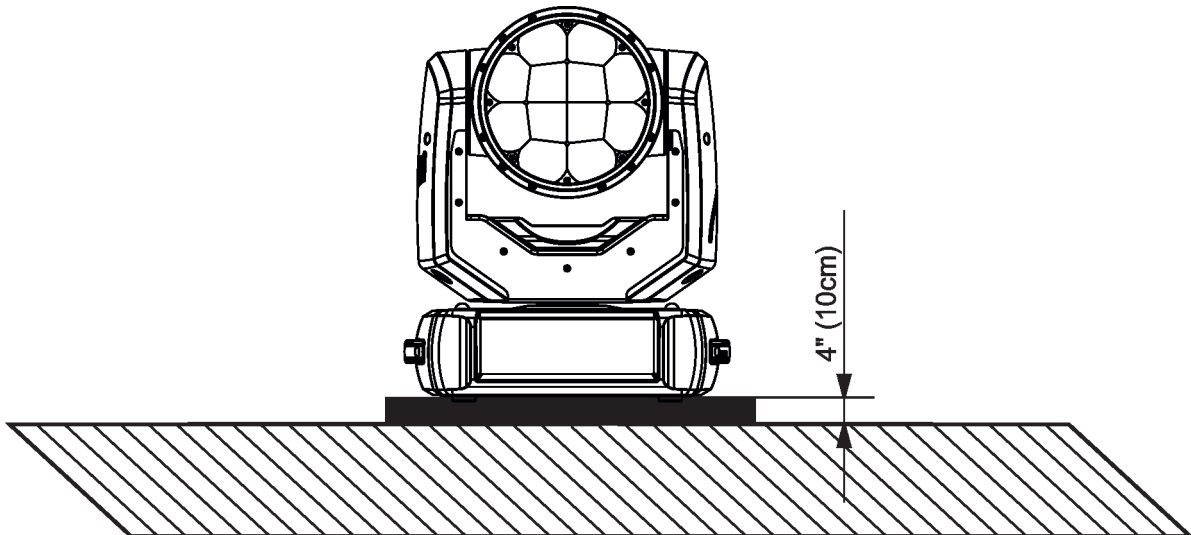

***When installing fixtures side-by-side,
avoid illuminating one fixture with another!***

***DANGER TO LIFE!
Before taking into operation for the first time, the installation has to be approved by
an expert!***

***In order to protect the internal parts of the head from the sun, the function
PARKING POSITION must be switched ON before switching the fixture off.***

The PARKING POSITION function is located on the Power/Special functions channel (115-118 DMX). If the function is on, the fixture will automatically detect via G-sensor whether the fixture is on the floor or hangs on the truss or is mounted sideways on the truss and moves the pan and tilt to the position (including movement of zoom to the front part of the head) in which the head will always face down. Owing this position of the fixture head, there is not chance to burn internal parts of the head by the sun light.

4.3 DMX-512 connection

The fixture is equipped with 5-pin XLR sockets for DMX input and output.

Only use a shielded twisted-pair cable designed for RS-485 and 5-pin XLR plugs and connectors in order to connect the controller with the fixture or one fixture with another.

To keep declared IP rating of the XLR panel connectors, all used XLR connectors and cables have to meet IP 65 rating.

DMX output

XLR socket (female)



- 1 - Shield
- 2 - Signal (-)
- 3 - Signal (+)
- 4 - Not connected
- 5 - Not connected

DMX input

XLR socket (male)

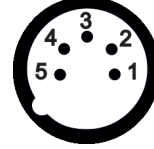

- 1 - Shield
- 2 - Signal (-)
- 3 - Signal (+)
- 4 - Not connected
- 5 - Not connected

Building a serial DMX-chain:

Connect the DMX output of the first fixture in the DMX-chain with the DMX input of the next fixture. Always connect one output with the input of the next fixture until all fixtures are connected. Up to 32 fixtures can be connected.

Caution: At the last fixture, the DMX cable has to be terminated with a terminator. Solder a 120 Ω resistor between Signal (-) and Signal (+) into 5-pin XLR plug and plug it into DMX output of the last fixture.

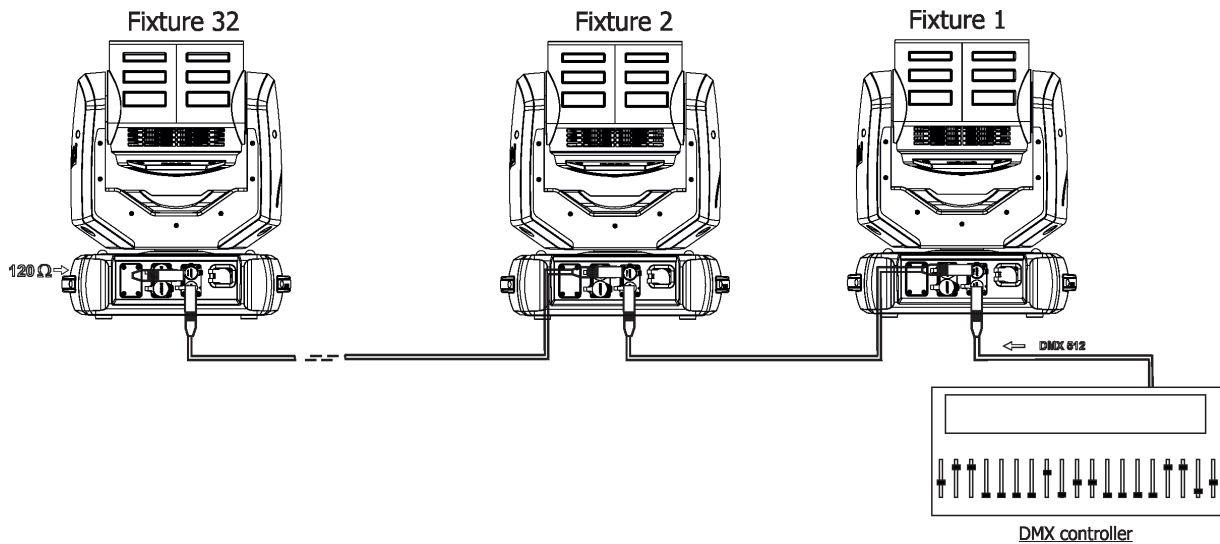

The Robin iBeam 350's panel connectors are dust and water protected according to IP 65 by mating with related cable connectors. They cannot stay disconnected outdoor. All unused panel connectors have to be sealed by the rubber caps.

4.4 Ethernet connection

To keep declared IP rating of the fixture, all used RJ45 and XLR connectors and cables have to meet IP 65 rating.

The fixtures on a data link are connected to the Ethernet with appropriate communication protocol (e.g. ArtNet). The control software running on your PC (or light console) has to support Art-Net protocol.

Art-Net communication protocol is a 10 Base T Ethernet protocol based on the TCP/IP. Its purpose is to allow transfer of large amounts of DMX 512 data over a wide area using standard network technology.

IP address is the Internet protocol address. The IP uniquely identifies any node (fixture) on a network.

Universe is a single DMX 512 frame of 512 channels.

The Robin iBeam 350 is equipped with two 8-pin RJ-45 socket for Ethernet input. Use a network cable category 5 (with four "twisted" wire pairs) and standard RJ-45 plugs in order to connect the fixture to the network.

RJ-45 socket (front view):

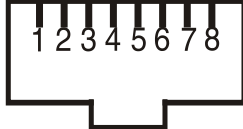

- | | |
|------------------|------------------|
| 1- TD+ | 5- Not connected |
| 2- TD- | 6- RX- |
| 3- RX+ | 7- Not connected |
| 4- Not connected | 8- Not connected |

RJ-45 plug (front view):

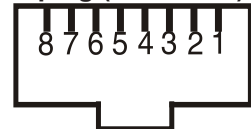

Patch cables that connect fixtures to the hubs or LAN sockets are wired 1:1, that is, pins with the same numbers are connected together:



If only the fixture and the computer are to be interconnected, no hubs or other active components are needed. A cross-cable has to be used:



If the fixture is connected with active Ethernet socket (e.g. switch) the network icon  will appear at the bottom right corner of the screen:

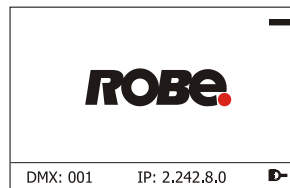

Ethernet operation

Connect the fixtures to the Ethernet network.

Option "Artnet (gMa1, MA2 or sACN)" has to be selected from "Ethernet Mode" menu on the fixture.

Set IP address (002.xxx.xxx.xxx / 010.xxx.xxx.xxx) and the Universe.

(DMX address=89)
IP address=002.168.002.004
Universe=1

(DMX address=23)
IP address=002.168.002.003
Universe=1

(DMX address=1)
IP address=002.168.002.002
Universe=1

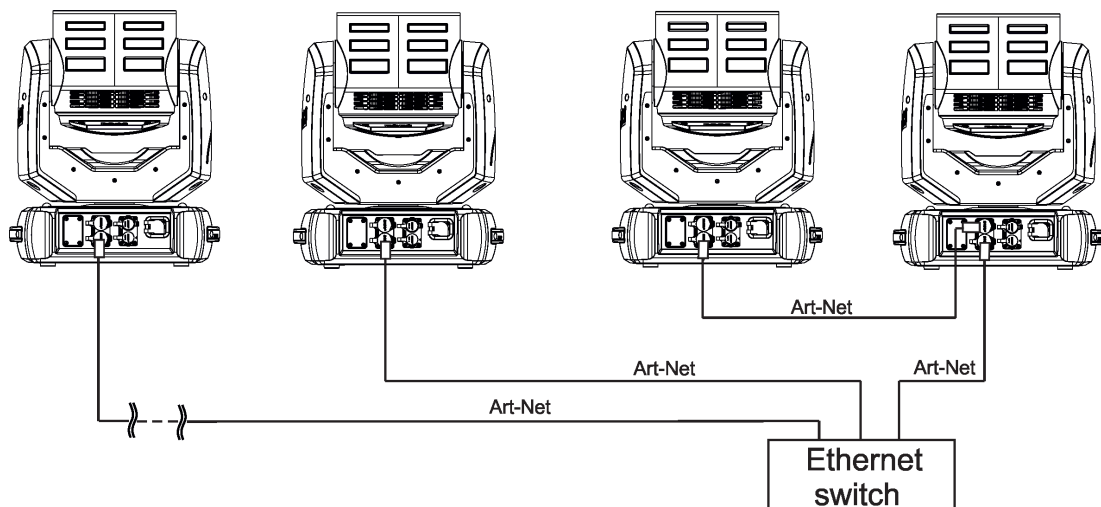

An advised PC setting: IP address: 002.xxx.xxx.xxx / 010.xxx.xxx.xxx (Different from fixture IP addresses)
NET mask: 255.0.0.0

The iBeam 350 is equipped with Ethernet Pass Through Switch which sustains Ethernet integrity, when the fixture has no power, it automatically maintains network connectivity.

If you use the Ethernet IN-OUT way for the Ethernet connection, max. 8 fixtures can be connected in the IN-OUT line.

Ethernet / DMX operation

Option "Artnet" (gMal or gMA2 or sACN) has to be selected from "Ethernet Mode" menu at first fixture.

Option "Ethernet To DMX" has to be selected from the menu "Ethernet Mode" at the first fixture (connected to the Ethernet) in the fixture chain, next fixtures have standard DMX setting.

Connect the Ethernet-input of the first fixture in the data chain with the network. Connect the DMX output of this fixture with the input of the next fixture until all fixtures are connected to the DMX chain.

Caution: At the last fixture, the DMX chain has to be terminated with a terminator. Solder a 120 Ω resistor between Signal (-) and Signal (+) into a XLR-plug and connect it in the DMX output of the last fixture.

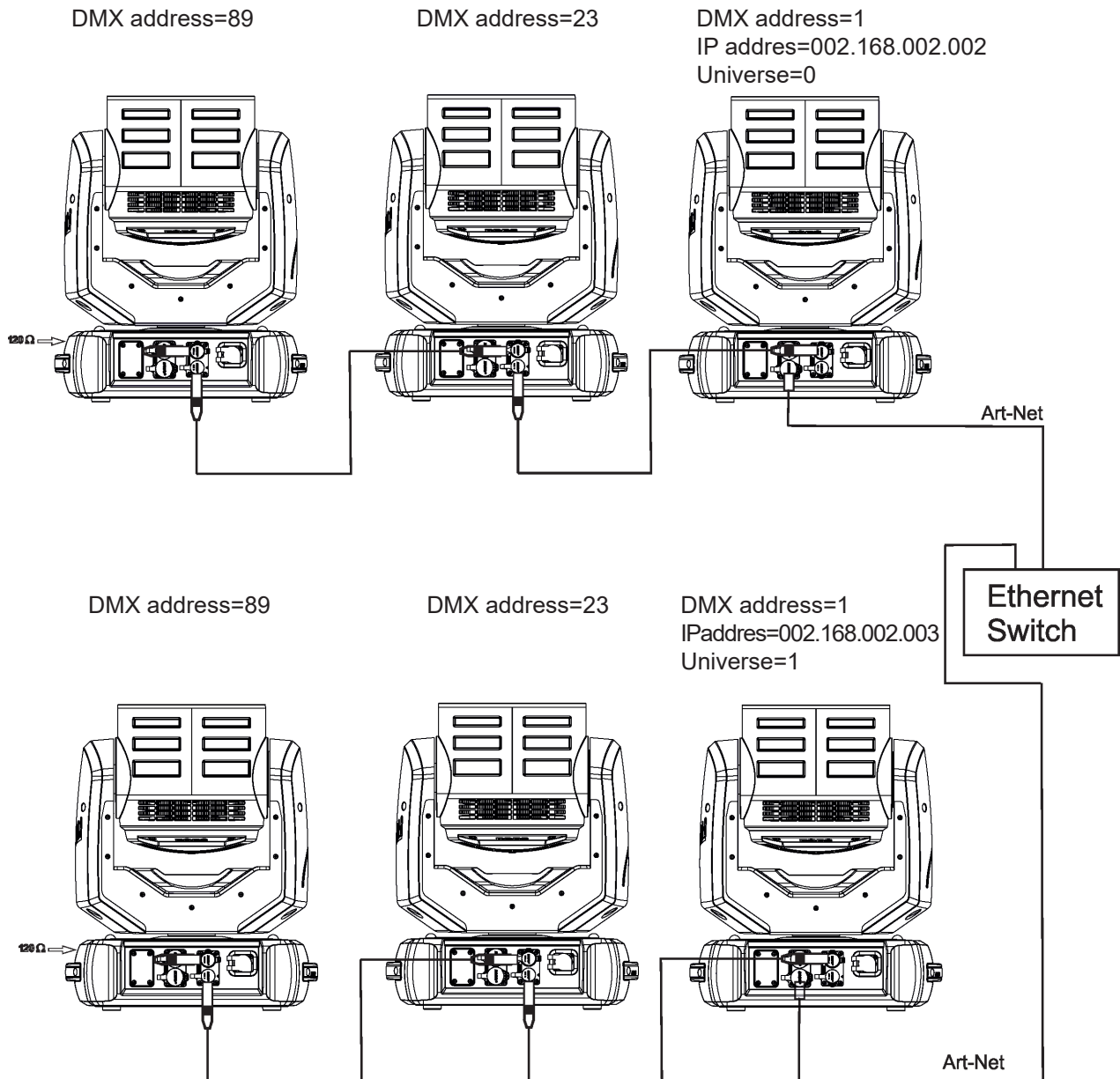

4.5 Wireless DMX operation

The integrated wireless DMX/RDM module allows receiving wireless DMX. The ROBE wireless DMX/RDM module has full support for wireless communication protocols at entertainment market. Modul is based on well known LumenRadio RF technology, with implemented wire interface for connection with Robe products. RF output for MCX interface antenna as standard output.

The item " Wireless " from the menu "DMX Input" allows you to activate receiving of wireless DMX (Personality--> DMX Input -->Wireless Input.). First two options from the "DMX Input" menu are stated in DMX chart as well (channel Power/Special functions , range of 10-19 DMX). If DMX input option is changed by DMX command, the change is permanently written into fixture's memory.

DMX range of 10-19 switching fixture to the wired/wireless operation is active only during first 10 seconds after switching the fixture on.

After switching the fixture on, the fixture checks both modes of receiving DMX in the following order:

1. For the first five seconds, the fixture receives DMX signal from the wired input. If the Power/Special functions channel is set at some DMX input option, the fixture will receive DMX value according to this option. If DMX input option is set to the wired input , this option is saved and checking procedure is finished. If DMX input option is not set, the fixture continues next 5 seconds in scanning wireless DMX signal-see point 2.

2. For the next 5 seconds the fixture receives wireless DMX signal and again detects if the Power/Special functions channel is set at some DMX input option, if not, the fixture will take option which is set in the fixture menu "DMX Input".

To link the fixture with DMX transmitter.

The fixture can be only linked with the transmitter by running the link procedure at DMX transmitter .

After linking , the level of DMX signal (0-100 %) is displayed in the menu item "Wireless State" (Information -->Wireless State).

To unlink the fixture from DMX transmitter.

The fixture can be unlinked from receiver via the menu item " Unlink Wireless Adapter" (Information--> Wireless State --> Unlink Wireless Adapter).

Note: If the option "Wireless In/XLR Out" is selected (Personality--> DMX Input -->Wireless In/XLR Out), the fixture receives wireless DMX and sends the signal to its wired DMX output. The fixture behaves as " Wireless/ Wired" adaptor.

Example:

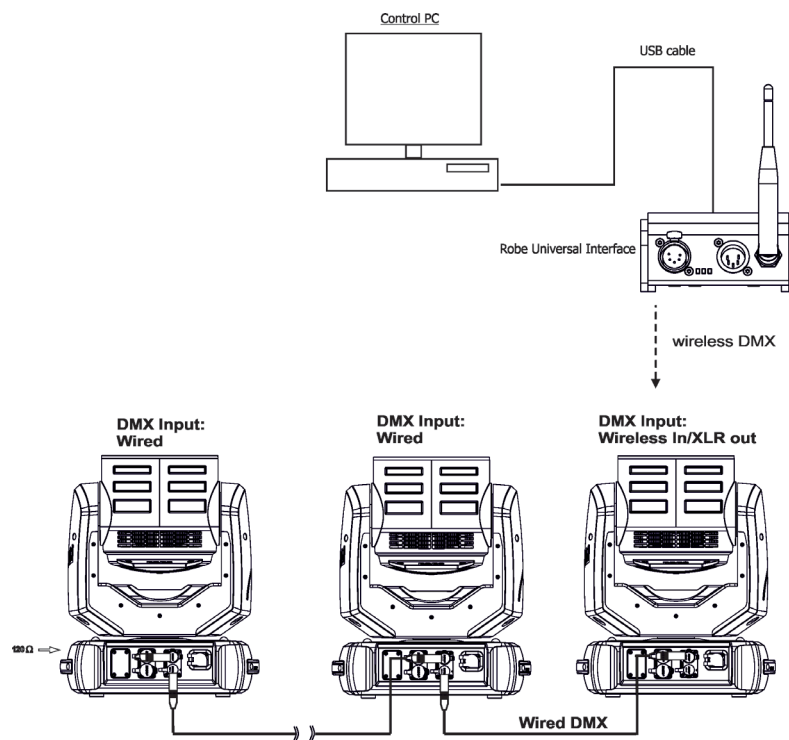

5. Checking the IP65 integrity of the fixture.

The Robin iBeam 350 is IP65 rated lighting fixture which has been designed to be protected against the ingress of dust and pressure water jets from any direction.

1. Smart pressure test - for this test serves the function "Pressure Test" in the tab Service. Unique testing procedure allows you easy testing of the IP65 integrity of the fixture. You do not need any external device connected to the fixture for running the test.

The fixture has to be connected to mains (must not be in Standby mode) and a head temperature (at pressure sensor) cannot be higher than 55°C. The pressure test takes about 8 minutes and can be run at earliest 10 minutes after closing light output of the fixture. The pressure test can be repeated at earliest 2 minutes after last pressure test.

The function "Pressure Test" should be run after the following actions:

- **unscrewing/screwing back any watertight cover**
- **checking/replacing dessicants in small boxes in fixture base**
- **replacing desiccant in tube in the fixture arm (tube with silica gel)**
- **replacing pan or tilt motor**

The pressure test can be also run by DMX command (channel Power/Special function) or from web interface REAP (Robe Ethernet Access Portal). During the pressure test fixture does not respond to DMX commands (except DMX values 92-93 on the channel Power/Special functions).

Examples of screens (front panel display) of the smart pressure test:

Fixture waits for 10 minutes period elapsing (inside of the fixture is too hot)

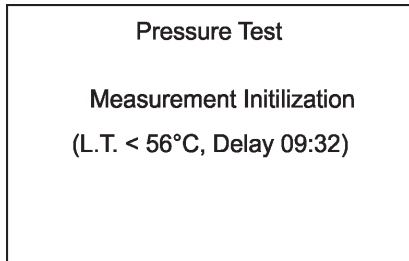

Fixture waits for 2 minutes period elapsing (pressure test was repeated too early)

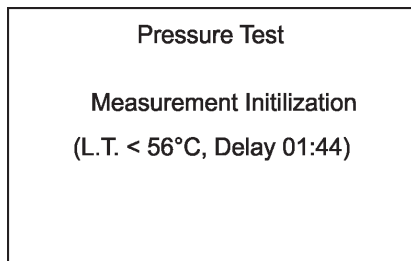

Setting fans

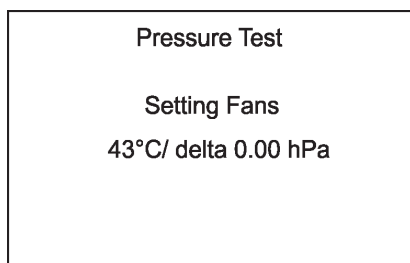

Test in progress

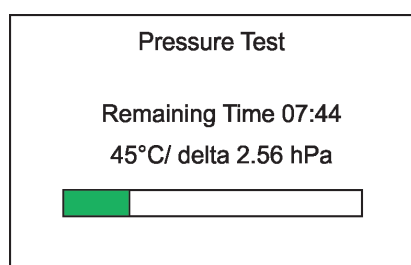

Legend:

07:44Remaining Time (minutes) to finish of pressure test.
45°C.....Temperature at pressure sensor.
delta 2.56 hPa...Pressure difference.
The pressure difference has to be >7 hPa for successful test.

Test passed

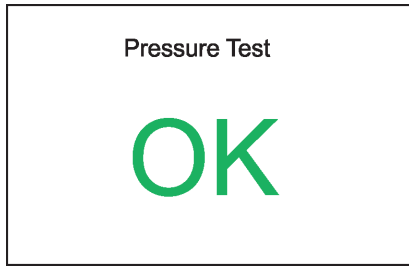

Test failed

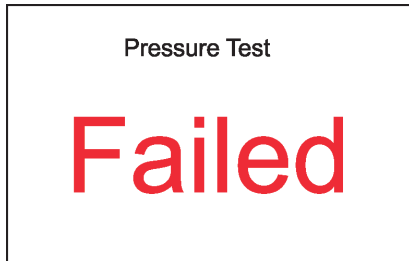

If the first pressure test failed and the second is OK, the fixture complies with IP65 integrity. If the pressure test twice fails despite checking of correct tightening of the cover screws and gaskets under covers, the fixture has to be tested by means of "Enhanced pressure test". For this type of pressure test is needed the Pressure IP Testing Set ROBE (P/N 10980659). Please ask your ROBE distributor for help.

The message "Valve Seal Error" means that valve or coil in the valve is defective or there is a connection problem.

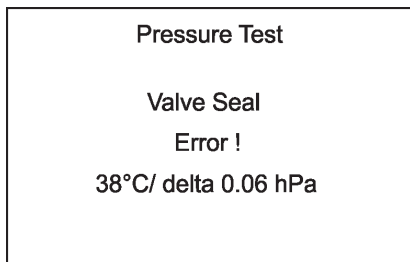

Check the connection between the valve and head, especially cable connector. Other reason can be faulty coil in the valve or faulty valve.

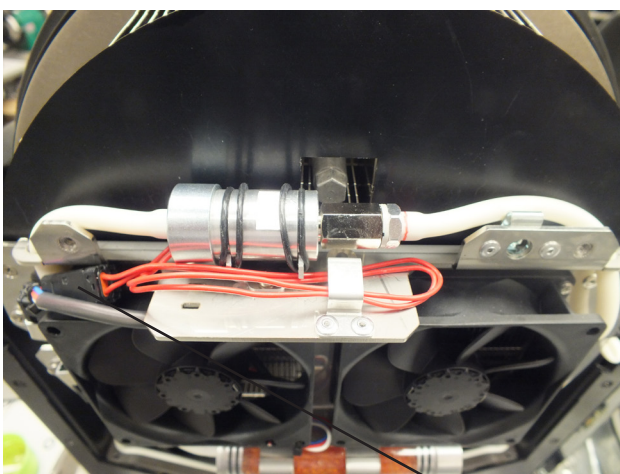

Cable connector

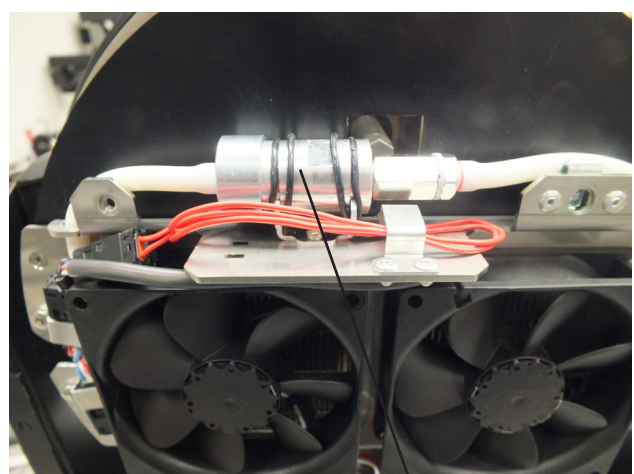

Valve

The message "Not Available At The Moment" means that the fixture is not connected to mains.

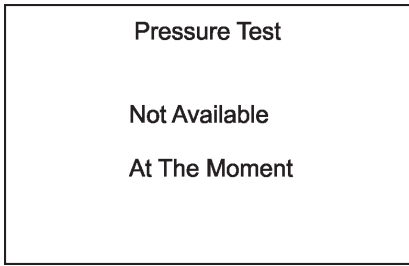

2. Enhanced pressure test - a special equipment Pressure IP Testing Set ROBE (P/N 10980659) is intended for this kind of pressure test. Only trained technician should handle the equipment.

Pressure IP Testing Set ROBE
in case:

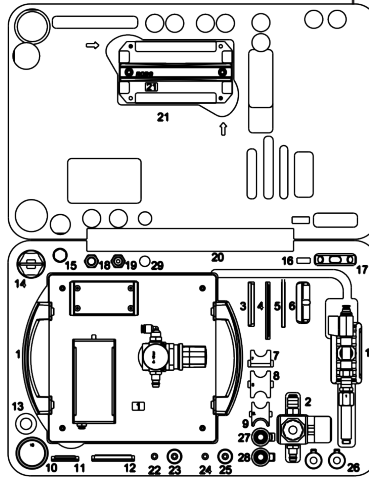

If this equipment is used for pressure test of the fixture, the following values of pressure have to be kept:

Underpressure test.

300 mbar for 1 minute, pressure fall can be to 10 mbar maximally.

Overpressure test

150 mbar maximally!

6. Operating the fixture at ambient temperatures below 0°C

Design of the iBeam 350 allows its operation at ambient temperature up to -30°C, but you have to take some specific into account before operating the fixture.

1. Fixture is not in Standby mode.

Ambient temperatures from 0°C to -10°C.

The fixture can be switched off but after powered it on, fixture reset can be delayed in range of 0 - 30 minutes depending on ambient temperature (max. delay is at low ambient temperature). This delay is caused by heating fixture effects on operating temperature. The fixture does not respond to DMX during heating the fixture on operating temperature.

We recommend to switch the fixture on at least 30 minutes before show.

Ambient temperatures from -11°C to -30°C.

The fixture should be permanently powered on in order to keep operating temperature of fixture's effects. If the fixture is switched off, reset of the fixture will last long time (up to 1 hour depending on ambient temperature) until fixture effects reach their operating temperature. T

2. Fixture is in Standby mode.

If the fixture is switched to Standby mode (fixture has to be connected to mains), the fixture keeps internal temperature on a level suitable for operation of fixture's effects without delay, heating up of the fixture inside is done automatically.

7. Standby mode

The fixture can be switched to Standby mode by means of web interface REAP or DMX command (channel Power/Special functions, DMX values 6-7).

Standby mode can be cancelled by means of web interface REAP, DMX command (channel Power/Special functions, DMX values 8-9) or by switching the fixture off and on.

Standby mode helps conserve power when a fixture is not in use, without fully powering it off. The max. power consumption of the fixture in Standby mode does not exceed 15 W (if the fixture is heated, power consumption is higher). Standby mode is indicated by a notice on the fixture display.

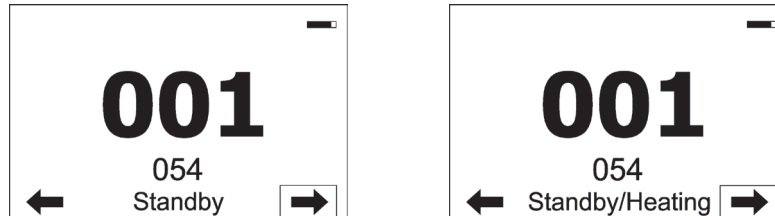

In the Standby mode, the fixture display is functional and can be used for setting of the fixture, but all motors and fans are deactivated, light output is closed.

As the fixture motors are deactivated, the fixture does not respond to DMX values controlling effects but the channel Power /Special functions can be used for fixture settings.

The fixture in Standby mode provides information for RDM and REAP and also can be set its behaviour by means of the RDM and REAP.

Main benefits of Standby mode:

- there is not time delay of fixture reset at ambient temperatures below 0°C.
- By means of REAP user has current information about fixture (settings, temperatures, state of desiccant in the fixture head).

8. Remotely controllable functions

Virtual colour wheel

This wheel contains 66 preset colours, rainbow effect in both directions is available.

Colour temperature correction (CTC)

This channel allows to set calibrated white colour from range of 8000K-2700K.

RGBW or CMY colour mixing system

The RGBW colour mixing system is based on red, green, blue and white high power LEDs. Option for switching the fixture to the CMY colour mixing system is available.

Colour Mix control

The Colour Mix control channel defines relation between virtual colours (CTO, Virtual colour wheel) and individual colour channels (RGBW, CMY)

"Virtual" = Virtual Colours (Virtual Colour Wheel)

"Colour mix" = Colour channels (RGBW/CMY)

DMX value	Function
0-9	Virtual colours ("Virtual" has priority)
10-19	Maximum mode (highest values have priority)
20-29	Minimum mode (lowest values have priority)
30-39	Multiply mode (multiply Virtual and Colour Mix)
40-49	Addition mode (Virtual + Colour Mix) - default
50-59	Subtraction mode (Virtual - Colour Mix)
60-69	Inverted Subtraction mode (Virtual - Colour Mix)
70-128	Reserved
129	Virtual colours ("Virtual" has priority)
130-254	Crossfade (crossfade between Virtual and Colour mix)
255	Colour channels ("Colour mix" has priority)

Zoom

Motorized zoom offers beam range of 3.8° to 52°.

Dimmer/Shutter unit

Smooth 0 - 100 % dimming is provided by the electronic control unit. This unit is also used for strobe effects with variable speed.

Pan/Tilt

Precise pan/tilt movement due to built-in electronic motion stabilizer. The electronic motion stabilizer ensures precise position of the fixture's head during its movement and reduces its swinging when the truss shakes.

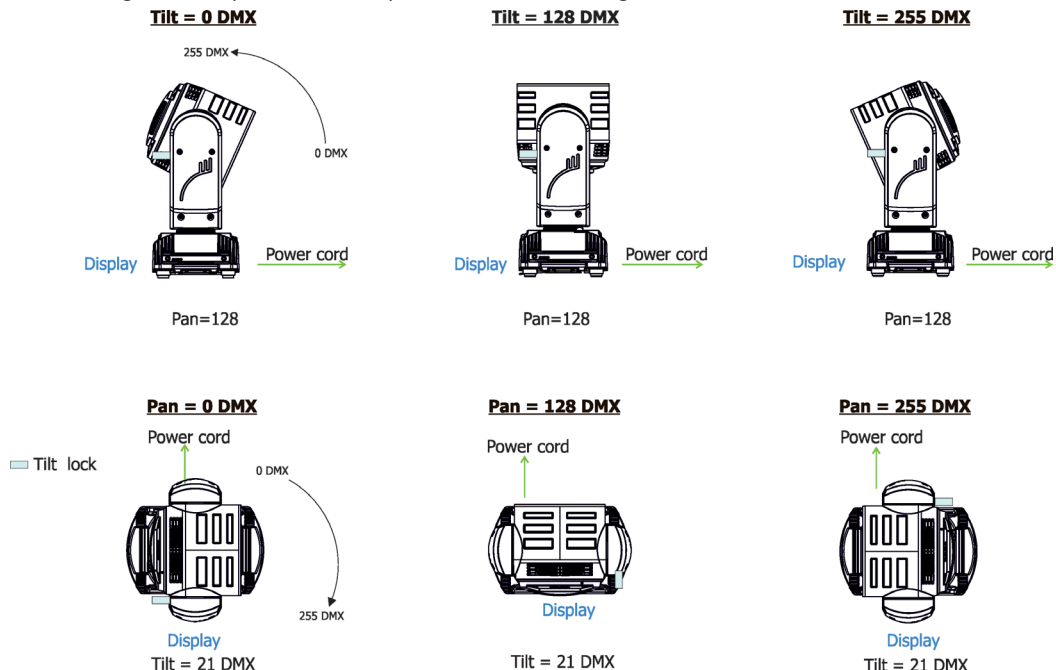

Pan movement range: 540° (450°reduced), tilt movement range: 228°.





9. Control menu map

Default settings=**Bold print**

Tab	Level 1	Level 2	Level 3	Level 4	Level 5	Level 6	
Addressing	Settings	DMX Address	001-512				
		DMX Preset	Mode 1 , Mode 2, Mode 3,				
		Ethernet Settings	Ethernet Mode	Disable			
				ArtNet			
				gMA1			
				gMA2			
				sACN			
				Ethernet To DMX	Off , On		
				IP Address/Net Mask	Default IP Address		
					Custom IP Address		
					Net Mask		
				ArtNet Universe	0-255		
				MANet settings	MANet/II Universe	01-256	
					MANet Session ID	01-32	
				sACN Settings	sACN Universe	00001-32000	
Information	Fixture Times	Power On Time	Total Hours				
			Resetable Hours				
			LEDs On Time	Red, Green, Blue:White			
		Fixture Temperatures	LEDs Temperature	Current			
				Maximum NonRes.			
				Maximum Res.			
			Base Temperature	Current			
				Maximum NonRes.			
				Maximum Res.			
			RAINS Status				
			Sensors Info				
		DMX Values	Pan				
			:				
			Dimmer Fine				
		Wireless State	Signal Quality				
			Unlink Wireless Adapter				
	Power Channel State						
	Software Versions	Display System					
		Module M					
		Module L					
		Module O					
		Module O					
		Module DL					
	Product IDs	Mac Address					
		RDM UID					
		RDM Label					
	View Logs	Fixture Errors					
		Fixture States	Power On				
			Power Off				
		Fixture Position					
		Fixture Temperatures	LEDs B.ITemperature				
			Base Temperatures				
			LEDs B.ITemperature				
		Sensors Logs					

Tab	Level 1	Level 2	Level 3	Level 4	Level 5	Level 6
		Pressure Tests Logs				
Personality						
	User Mode	User A Settings				
		User B Settings				
	DMX Presets	Mode 1				
		Mode 2				
		Mode 3				
		View Selected Preset				
	DMX Input	Wired Input				
		Wireless Input				
		Wireless In/XLR Out				
	Pan/Tilt Settings	Pan Reverse	Off, On			
		Tilt Reverse	Off, On			
		Pan/Tilt Feedback	Off, On			
		Pan/Tilt mode	Time			
			Speed			
	Blackout Settings	Blackout During M.C.	Off, On			
		Blackout while:	Pan/Tilt moving	Off, On		
	Colour Mixing Mode	RGBW				
		CMY				
	White Point 8000K	Off, On				
	Frequency Setup	300Hz				
		600Hz				
		1200Hz				
		2400Hz				
		High				
		Adjust				
	Tungsten Eff. Sim.	Off				
		750W				
		1000W				
		1200W				
		2000W				
		2500W				
	Init Effect Positions	Pan	0-255			
		:				
		Dimmer Fine	0-255			
	Reset Effect Positions					
	Screen Settings	Display Intensity	1-10			
		Screen Saver Delay	Off-10min.			
	Temperature Unit	°C, °F				
	Fan Settings	Fan Mode	Auto			
			High			
			Quiet			
		Quiet-Blackout Fan Off	Off, On			
	Dimmer Curve	Linear				
		Square Law				
	Date & Time Settings					
	Default Settings					
Manual Control	Reset Functions	Total System reset				
		Pan/Tilt reset				
		Zoom Reset				
		Flower E. Reset				
	Manual Effect Control	Pan	0-255			

Tab	Level 1	Level 2	Level 3	Level 4	Level 5	Level 6
		:				
		Dimmer Fine				
Stand -Alone	Test Sequences	Dynamic Mode				
		Static Mode	Pan	0-255		
			Tilt	0-255		
			Zoom	0-255		
	Preset Playback	None				
		Test				
		Prog. 1				
		Prog. 2				
	Play Program	Play Program 1				
		Play Program 2				
	Edit Program	Edit Program 1	Start Step	1-68		
			End Step	1-68		
			Edit Program Steps	Step 1	Pan	0-255
				:	:	
				:	Dimmer Fine	0-255
				:	Step Time	0-25,5 sec.
				Step 68	Pan	0-255
					:	
					Dimmer Fine	0-255
					Step Time	0-25,5 sec.
Service	Pressure Test					
	Adjust DMX Values	Pan	0-255			
		:				
		Dimmer Fine	0-255			
	Calibrations	Calibrate Effects	Pan	0-255		
			Tilt:	0-255		
			Zoom	0-255		
		Calibrate colours	Red	0-255		
			Calibrate colours	Red	X,Y, Int.,Temp.	
				Green	X,Y, Int.,Temp.	
				Blue	X,Y, Int.,Temp.	
				White	X,Y, Int.,Temp.	
			Load Default Calibrations			
			LEDs Current Calibration			
	Update Software					

10. Control menu











The Robin iBeam 350 is equipped with the QVGA screen with battery backup and four control buttons which allow you to set the fixture's behaviour according to your needs, obtain information on its operation, test its various parts and program it, if it has to be used in a stand-alone mode. The fixture supports NFC (Near-Field Communication).

NFC interface and control buttons on the front panel



[ESCAPE] button used to leave the menu without saving changes.
[NEXT] , [PREV] buttons for moving between menu items and symbols, adjusting values.
[ENTER/Display On] button used to enter the selected menu (menu item) and to confirm adjusted value.
If the fixture is disconnected from mains, the button switches the screen on.

Icons used in the screen menu:

-  - [back arrow] used to move back to the previous screen (menu).
-  - [up arrow] used to move up on the previous page.
-  - [down arrow] used to move down on the next page.
-  - [confirm] used to save adjusted values, to leave menu or to perform desired action.
-  - [cancel] used to leave menu item without saving changes.
-  - [confirm+copy] used to save adjusted values and copy them to the next prog. step.
-  - [warning icon] used to indicate some error which has occurred in the fixture.
-  - [Ethernet] used to indicate Ethernet connected.
-  - [display turn] used to turn the display by 180°.
-  - [slider control] used to recall slider system for setting desired value.
-  - [keyboard control] used to recall keyboard system for setting desired value.

The menu page displays icons for each function that you can perform from the screen. After switching the fixture on, the screen shows the screen with the ROBE logo:

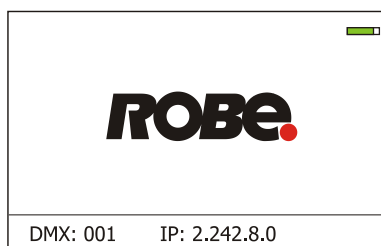

Note: The green icon at the top right corner of the screen indicates the level of the display battery charging. If

the whole icon is green, the battery is fully charged while the red icon indicates exhausted battery. The battery charges during fixture operation, its charging lasts cca 6 hours.

We recommend that the fixture should be in operation at least 7 hours per week to keep the battery fully charged. If you switch the fixture on and this screen will not appear till 1 minute, switch the fixture off and on again. If the screen lights, the battery is exhausted. In case the screen still does not light, the battery is faulty.

This is also indicated by an error message "Faulty battery" and if such an error message appears the battery should be replaced immediately. The lifetime of the battery is highly dependent on ambient temperature (and consequently on base temperature). If the maximum ambient temperatures (as recorded and displayed in menu: Information -> Fixture Temperatures -> Ambient Temperature -> Maximum NonRes.) are kept within the specified limits, the battery should last for at least two years. Should the ambient temperatures exceed the specified maximum temperature, the lifetime of the batteries could be considerably shortened even up to just one year or less and also result in physical damage (battery leakage) or unreliable fixture functions.

Damage caused by batteries failed due to exceeded maximum ambient temperature cannot be claimed under warranty terms.

Press the [ENTER/Display On] button to enter the " Address" menu.

Any item may be selected from a screen by pressing the [NEXT] or [PREV] buttons to scroll through list items.

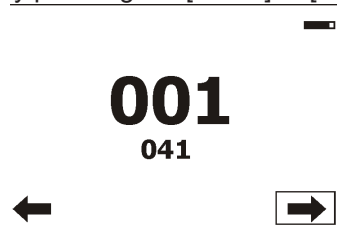

With each press, the next item is highlighted. Press [ENTER/Display On] to select the highlighted item.

Before first fixture operation, set current date and time in the menu "Date &Time Settings" (menu path: Personality--> Date &Time Settings).

As the fixture can be operated at wide range of ambient temperatures, suitable environment has to be maintained in inside of the fixture. The following messages under DMX address inform you about fixture status.

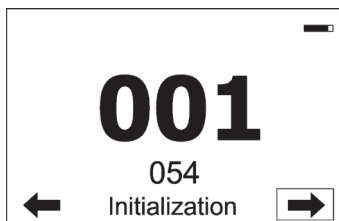

The fixture is waiting for finishing all reset procedures. Fixture does not respond to DMX.



The fixture is waiting for reaching operating temperature of the fixture inside (inside temperature is below 0°C). Fixture does not respond to DMX.

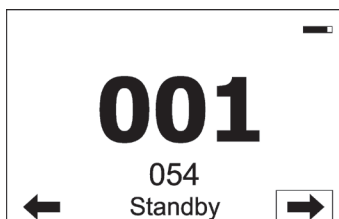

The fixture is in standby mode. Fixture effects does not respond to DMX, but display is active. Fixture sends its statuses and recorded physical values (temperature, humidity, pressure) to the REAP.

Locking/unlocking the screen

To lock the screen, display the screen with ROBE logo, touch the [ESCAPE] button and slide your finger clockwise in a circular track of 360° across buttons [ESCAPE] --> [NEXT] --> [ENTER/Display On] --> [PREV]--> [ESCAPE]. The sign "Buttons are locked" will appear on the screen. If this sign will not appear, repeat finger sliding again with a different speed.

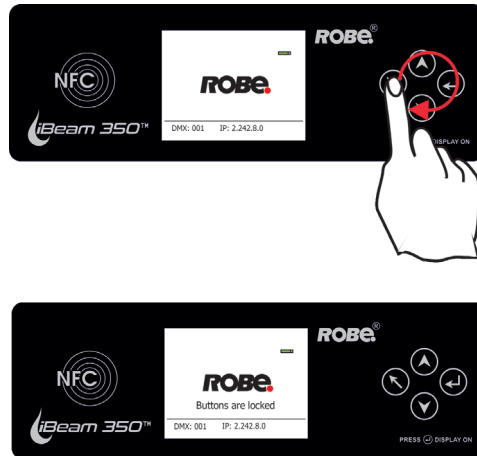

To unlock the screen, touch the [ESCAPE] button and slide your finger clockwise in a circular track of 360° across buttons [ESCAPE] --> [NEXT] --> [ENTER/Display On] --> [PREV]--> [ESCAPE]. The sign "Buttons are locked" will disappear from the screen. If this sign still remains on the screen, repeat finger sliding again with a different speed.



10.1 Tab " Address"



DMX Address - Select the menu to set the DMX start address.

DMX Preset - Use the menu to select desired channel mode.

View Selected Preset - Use the menu to display channels included in the selected mode.

Ethernet Settings - The menu allows all needed settings for the Ethernet operation

Ethernet Mode

Disable - The option disables Ethernet operation.

Artnet - Fixture receives Artnet protocol

gMA1 - Fixture receives MANet 1 protocol

gMA2 - Fixture receives MANet 2 protocol

sACN - Fixture receives sACN protocol

Ethernet To DMX - Fixture receives protocol from the Ethernet input and sends DMX data to its DMX output (fixture works as an "Ethernet/DMX converter", next fixture can be connected to its DMX output and you can build a standard DMX chain by connecting another fixtures.

Only one fixture has to be connected to the Ethernet.

IP Address/Net Mask - Select this menu to set IP address. IP address is the Internet protocol address. The IP uniquely identifies any node (fixture) on a network.

There cannot be 2 fixtures with the same IP address on the network!

Default IP Address -Preset IP address, you can set up only first byte of IP address (2 or 10) e.g. **002.019.052.086**.

Custom IP Address - The option enables to set up all bytes of IP address.

Net Mask - The option enables to set up all bytes of Net Mask.

ArtNet Universe - Use this item to set a Universe (0-255). The Universe is a single DMX 512 frame of 512 channels.

MANet Settings - Use this menu to set parameters for MANet operation.

MANet I/II Universe - The value of this item can be set in range 1-256.

MANet Session ID - The value of this item can be set in range 1-32.

sACN Settings - Use this menu to set parameters for sACN operation.

sACN Universe - The value of this item can be set in range 1-32000.

10.2 Tab "Information"



Fixture Times - The menu provides readouts of fixture operation hours and air filters using hours.

Power On Time - Select this menu to read the number of fixture operation hours.

Total Hours - The item shows the total number of the operation hours since the Robin iBeam 350 has been fabricated.

Resetable Hours - The item shows the number of the operation hours that the Robin iBeam 350 has been powered on since the counter was last reset.

In order to reset this counter to 0, touch the text box next to the item "Resetable Hours:"

LEDs On Time - Select this menu to read the number of operation hours of colour LEDs.

Fixture Temperatures - The menu is used to view temperatures of the fixture's inside.

LEDs temperatures - The menu shows temperature on the LEDs PCB in the fixture head.

Cur. - A current temperature of the LEDs PCB.

Max. - A maximum temperature of the LEDs PCB since the fixture has been fabricated.

Max. Res. - A maximum temperature of the LEDs PCB since the counter was last reset.

In order to reset some counter to 0, touch desired text box under item "Max.Res."

Base Temperature - The menu shows temperature in the fixture base.

Current - A current temperature in the fixture base.

Maximum NonRes. - A maximum temperature in the fixture base since the fixture has been fabricated.

Maximum Res. - A maximum temperature in the fixture base since the counter was last reset.

In order to reset this counter to 0, touch the text box next to the item "Maximum Res."

RAINS Status - The menu item gives you information about environment in the fixture.

RAINS (Robe Automatic Ingress Neutralization System) manages humidity, temperature and pressure control using an active monitoring system to automatically remove any moisture detected within the fixture and provides permanent monitoring to ensure peak performance of the fixture.

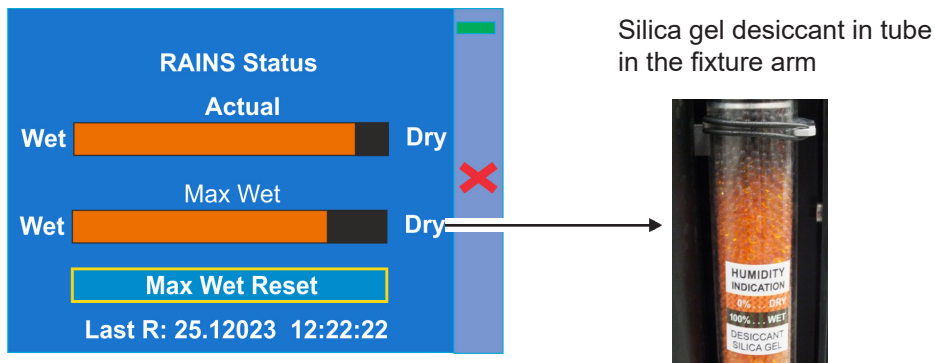

The bar chart **Actual** informs you about current humidity in the fixture. The bar chart changes depending on humidity, temperature and pressure in the fixture. The bar chart depends on current conditions in the fixture and can be different at start of fixture operation, after 10 minutes of its operating, after closing fixture dimmer etc.

The bar chart **MAX WET** informs you about maximum humidity achieved in the fixture since the chart was last reset. The bar chart also informs you about saturation of silica gel with water in tube in the fixture arm and is deciding indicator for its checking and replacement.

The option **MAX WET reset** resets the bar chart MAX WET. Date and time of last reset is displayed below the option.

Examples of RAINS statuses:

Dry desiccant in tube in the fixture arm

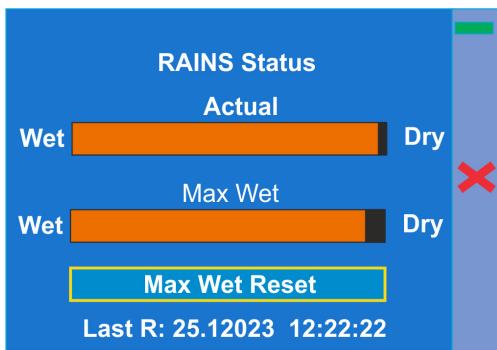

Desiccant in tube in the fixture arm partially saturated with water

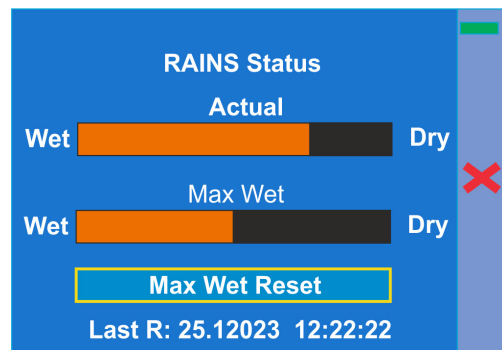

Desiccant in tube in the fixture arm fully saturated with water

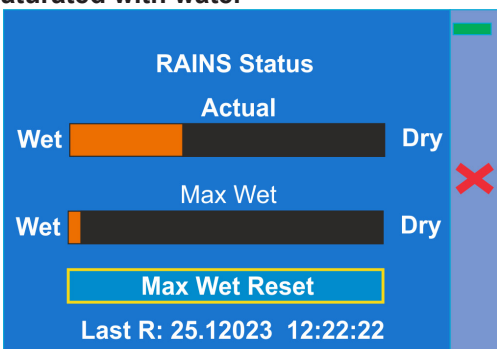

Desiccants in tube in the fixture arm is saturated with water and should be replaced.

After replacing it, reset the item MAX WET.

It is not necessary to replace silica gels desiccants in plastic boxes in the fixture base. These desiccants should be checked (and replaced if it is needed) at removing base cover, e.g. at some service intervention.

Sensors Info - The menu items shows you current conditions in the fixture head (at pressure sensor): temperature, relative humidity and pressure in the fixture.

DMX Values - The menu is used to read DMX values of each channel received by the fixture.

Wireless State - The menu serves for reading of the wireless operation status.

Unlink Wireless Adapter - The item serves for unlinking the fixture from DMX transmitter.

Power Channel State - The menu item shows state of the Power/Special functions switches.

Software Version - Select this item to read the software version of the fixture modules:

Display System - a display processor on the display board in the fixture base

Module M - a Pan/Tilt processors

Module L - a LEDs driver

Module O - a zoom control

Module DL - a data logger

Wireless - a wireless DMX module

Product IDs - The menu is used to read the MAC Address ,RDM UID and RDM Label.

View Logs - Use this menu to read fixture's data which have been recorded during fixture operation. This collected data allows easier troubleshooting.

Fixture Errors - Use this menu to read fixture errors which have occurred during fixture operation.

Fixture States - Recorded following actions: Fixture On, Fixture Off.

Fixture Position - Recorded installation positions of the fixture:

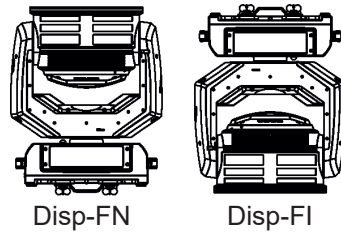

Fixture Temperatures - Recorded temperatures which have exceeded defined levels.

Sensor Logs - In the menu item are recorded physical values in the fixture: temperature, relative humidity and pressure.

Pressure Test Log - In the menu item are recorded values related to executed pressure tests: date and time, temperature, pressure difference, duration of pressure test and its result.

Note: The log buffer can contain 8000 records max. If the buffer is full, old data will be overwritten.

10.3 Tab "Personality"



User mode - The Robin iBeam 350e allows you to recall two user settings. After switching the fixture on for the first time, the User A settings is active. Now all changes made in the "Personality" menu, "Addressing" menu and the "Preset Playback" item from the "Stand-alone" menu are saved to the User A settings. If you now select the User B settings, from this moment the changes made in these menus will be saved to the User B settings. After switching the fixture off and on, the User B setting is active. In this way you may use the two fixture operating behaviours.

User A Settings - the function recalls the user A settings.

User B Settings - the function recalls the user B settings.

DMX Preset - Use the menu to select desired channel mode.

View Selected Preset - Use the menu to display channels included in the selected mode.

DMX Input - Use the menu to select mode of DMX signal receiving.

Wired Input - DMX signal is received by means of the standard DMX cable.

Wireless Input - DMX signal is received by means of the inbuilt wireless module.

Wireless In/XLR Out - the fixture receives wireless DMX and sends the signal to its wired DMX output.

The fixture behaves as "Wireless/Wired" adapter.

The options "Wired Input" and "Wireless Input" are also stated in DMX chart (channel Power/Special functions).

Note. If the wireless module is not installed in the fixture, the following message will appear:

DMX Input Set to Wired

Wireless Module Missing

If the fixture is not connected to mains, the message "Not Available In Offline Mode" will appear after entering the menu DMX Input. To enter this menu, the fixture has to be connected to mains.

Pan/Tilt Settings - Use the menu set behaviour of both pan and tilt movements.

Pan Reverse - The item allows to invert pan movement.

Tilt Reverse - The item allows to invert tilt movement.

Pan/Tilt Feedback - The item allows to return the mowing head to the required pan/tilt position after changing the position by an external force if this option is set on.

Note. Be careful, the Pan/Tilt Feedback should be permanent On, the option Off is not suitable for standard operation and the head of the fixture can be damaged!

Pan/Tilt mode - Use this menu to set the mode of the pan/tilt movement

Time mode - The pan and tilt will move with different speeds and they will come at the same time to the end point of their tracks (pan and tilt use their optimal speeds).

Time of the pan/tilt movement (25.5 sec. max.) is set by the channel "Pan/Tilt speed, Pan/Tilt time".

Speed Mode - Both Pan and tilt will move with the same speed as adjusted at the channel "Pan/Tilt speed, Pan/Tilt time".

Pan/Tilt EMS - Built-in electronic motion stabilizer ensures precise position of the fixture's head during its movement and also reducing its swinging when the truss shakes.

Blackout Settings - Use the menu if you need to close the light output under certain conditions which are described below

Blackout DMC - Blackout during movement correction. Set this option On if you wish to close light output during the time when the head goes to its correct position, which has been changed by an external force.

Active Blackouts - Use this menu if you wish to close the light output during effect changes.

Pan/Tilt Moving - The menu item enables to close light output while the pan/tilt coordinates are changing.

White Point 8000K - If the function is on, the CTC channel allows to set desired white in range of 8000K-2700K (0 DMX=8000K, 255 DMX=2700K). Necessary condition is, that RGBW channels have to be full or set at the same DMX values, e.g. 150.

If this function is off, the range of whites is not uniform and may be different for each fixture.

Colour Mixing Mode - This item allows switching into RGBW or CMY mode. In the CMY mode, the white(8bit)/white (16) bit channels are not active.

Tungsten Effect Sim. - This function simulates behaviour of a halogen lamp during dimming at calibrated whites 2700K, 3200K. You can select from various lamp wattage simulation: 750W, 1000W, 1200W, 2000W, 2500W.

Dimmer Curve - You can select desired dimmer curve: Linear or Square Law.

Frequency Setup - The function allows you to set the PWM (Pulse Width Modulation) output frequency of LEDs to 300Hz, 600Hz, 1200Hz, 2400Hz or High.

Adjust - The menu item allows you fine adjustment of the LED frequency around selected frequency.

Tungsten effect simulation - This function simulates behaviour of a halogen lamp during dimming at calibrated whites 2700K-4200K. You can select from various lamp wattage simulation: 750W, 1000W, 1200W, 2000W, 2500W.

Init Effect Positions - Use the menu to set all effects to the desired positions at which they will stay after switching the fixture on without DMX signal connected.

Reset Effect Positions - Use the menu to set all effects in the menu "Init Effect Positions" to default values.

Screen Settings - Use this menu to change the touch screen settings.

Display Intensity - The item allows to control the intensity of the screen (1-min., 10-max.).

Screen saver Delay - The item allows you to keep the screen on or to turn it off automatically after 1-10 minutes after last touch (or pressing any button on the control panel).

Touchscreen Lock - The item allows you to lock the screen after last touch (or pressing any button on the control panel). The time delay can be set in range of 1-10 minutes. To unlock the screen, press the [ENTER/Display On] button.

Recalibrate Touchscreen - The item starts calibration of the touchscreen. Follow the instructions on the screen.

Display Orientation - The menu allows to change display orientation.

Normal - Standard display orientation if the fixture is placed horizontally (e.g. on the ground).

Inverted - This function rotates menu 180 degrees from current orientation.

Auto - The option activates a gravitation sensor for automatic screen orientation.

Note: **Auto** option is set as default. You change the display orientation by touching the icon  on the display, and the option set in the "Display Orientation" menu is temporarily overridden.

Temperature unit - Use the menu item to change temperature unit from °C to °F.

Fan Settings - Use the menu to set fans operation mode.

Fan Mode - Use the menu to set the fixture fans to max. power mode (option "High") or to the auto-control mode (option "Auto"). The third option "Quiet" allows you to set desired fan noise. The light output of the fixture is reduced at low speeds of fans.

Quiet - Blackout Fan Off - The menu item allows you to stop all fans in the fixture (option "On") when its light output is closed (shutter in range of 0-31 DMX or dimmer in 0 DMX).

Dimmer Curve - Use the menu to select desired dimmer curve: Linear or Square Law.

Date & Time Settings - Use this menu to set current date and time for the fixture log system (menu "View Logs"). Set this menu item before first fixture operation.

Password Protection - allows to enter password in order to prevent unauthorized person from changing setting of the fixture. Password is set to 7623 and cannot be changed.

Reset Web Password - The menu item allows you to reset a password for access to the REAP (default password: 2479, user: robe).

Default Settings - The menu item allows to set all fixture parameters to the default (factory) values.

10.4 Tab "Manual Control"



Reset Functions - The menu allows to reset the fixture either per function modules or all modules together.

Total System Reset - The item resets all function modules.

Pan/Tilt Reset - The item resets the pan and tilt movement.

Zoom Reset - The item resets the zoom module.

Manual Effect control - Use the menu to control all fixture channels by means of the control panel.

10.5 Tab "Stand-alone"



Test Sequences - Use the menu to run a test/demo sequences without an external controller, which will show you some possibilities of using Robin iBeam 350.

Dynamic Mode - This mode uses all Robin iBeam 350 functions including pan/tilt movement and therefore is good for a complete introduction of the fixture.

Static Mode - This mode is suitable for projections on the wall, ceiling or ground without any pan/tilt movement. Adjust the pan, tilt and zoom to desired positions and start test sequences by touching the green ► icon.

Preset Playback - This menu allows you to select the program which will be played in a loop after switching the fixture on (the option is commonly used in a stand-alone operation without an external controller).

None - The option disables "Presetting playback" function.

Test - The option starts the test sequences.

Prog. 1 - The option starts user program No. 1.

Prog. 2 - The option starts user program No. 2.

Play program - Use the menu to run desired program in a loop.

Play Program 1 - The option starts user program No.1.

Play Program 2 - The option starts user program No. 2.

Edit Program - Use the menu to create or to edit desired program. The Robin iBeam 350 offers 3 free programs, each up to 68 steps.

Edit Program 1 - The option allows to edit user program No.1.

Edit Program 2 - The option allows to edit user program No.2.

To edit program:

1. Touch the item which you want to edit ("Edit Program 1", "Edit Program 2").
2. Touch the item "Edit Program Steps".
3. Touch the item "Step 1".
4. From the list of effects touch desired effect and set its value. Browse through the list by touching the [up arrow] and [down arrow] and set all desired effects.

An item "Step Time" (value of 0-25.5 sec.) is the time during which effects last in the current step

5. Save adjusted effects to the current step by touching the [confirm] or save and copy them to the following step by touching the [confirm+copy]. By touching the text box "Preview" next to the current program step you can view created scene.

6. Repeat the steps 4 and 5 for next program steps.

7. After editing desired program steps, adjust the length of the program by touching the text boxes "Start Step" and "End Step".

Meaning of the icons used in the "Edit Program" menu:

↓ - moves down on the next page

✓ - saves adjusted values and leaves menu

↑ - moves up on the previous page

✓+ - saves values to the current step and copy them to the following prog. step

✗ - leaves menu without saving values

10.6 Tab "Service"



Pressure Test - The menu item runs a procedure which checks the IP65 integrity of the fixture. The fixture has to be connected to mains and the head temperature (at pressure sensor) cannot be higher than 55°C. The pressure test lasts about 8 minutes and can be run at earliest 10 minutes after closing light output (shutter closed) of the fixture. The pressure test can be repeated at earliest 2 minutes after last pressure test.

For more details of pressure test please see the chapter Checking the IP65 integrity of the fixture.

Adjust DMX Values - The menu allows you to set all effects to desired positions before fine calibration of the effects .

Calibrations - This menu enables fine calibration of fixture effects and download default calibration values.

Calibrate Effects - The menu allows the fine adjustment of effects.

Pan- a pan position fine adjustment

Tilt - a tilt position fine adjustment

Zoom - a zoom module fine adjustment

Calibration of the effects via the control board

1. Disconnect DMX controller from the fixture and enter the "Calibrate Effects" menu.
2. Use the [up arrow] and [down arrow] to find "Pan" and touch it to enter the fine effect adjustment screen.
3. Set desired value and save it by touching the [confirm].
4. Repeat steps 2 and 3 for next item
5. After calibrating all effects, touch the [confirm] to save all adjusted values and reset the fixture.

Calibrate Colours - The menu serves for calibration of white colours in a factory, user should not change values in the menu

Calibration protocol:

Effect	Mode 1	Mode 2	Mode 3
Pan-fine adjustment	channel 23	channel 17	channel 25
Tilt - fine adjustment	channel 24	channel 18	channel 26
Zoom - fine zoom adjustment	channel 25	channel 19	channel 27

Load Default Calibrations - The item loads default (factory) calibration values.

LEDs Current Calibration - This process waits about 5 minutes and after its finishing the sign "Current Calibration DONE" will appear on the display. The procedure should be run if some colour nonuniformity has occurred during fixture operation.

Important. The procedure must be run after each LEDs PCB (RB 8438) changing, otherwise damage of the LEDs PCB may occur! This calibration of LEDs current must be run before dimmer activation!

Note: Calibration of LEDs current can be also run by means of the RDM manager ver. 1.0.12 and higher (LED Driver -->Start Current Calibration).

Update software - The menu item allows you to update software in the fixture via either serial or USB port of PC. The following items are required in order to update software:

- PC running Windows or Linux or macOS
- DSU file
- Flash cable RS232/DMX (P/N13050624) or Robe Universal Interface / Robe Universal interface WTX.

To update software in the fixture:

1. DSU file is available from Robe web site at WWW.robe.cz.

File with extension zip is intended for Windows (used and tested from XP to W10 on 32/64bit systems).

File with extension tbz is intended for Linux (used and tested on Debian and Ubuntu 32/64bit).

File with extension dmg is intended for macOS (used and tested on OSX up to Sierra) XQuartz required, install it from <https://www.xquartz.org/>

Save the download file to a folder on your computer.

In case that you use windows, extract files in the zip file (e.g. DSU_RobiniBeam 350_18051835.zip)

2. Disconnect the fixture from DMX controller.

3. If you use the flash cable RS232/DMX, connect a serial port of your computer with DMX input of the fixture by means of the cable (probably you will need some USB to RS 232 converter if your computer has USB ports only).

If you use the Robe Universal Interface, connect a USB port of your computer with the Robe Universal Interface by means of the USB cable and DMX input of the fixture with the DMX output of the Robe Universal Interface via a DMX cable.

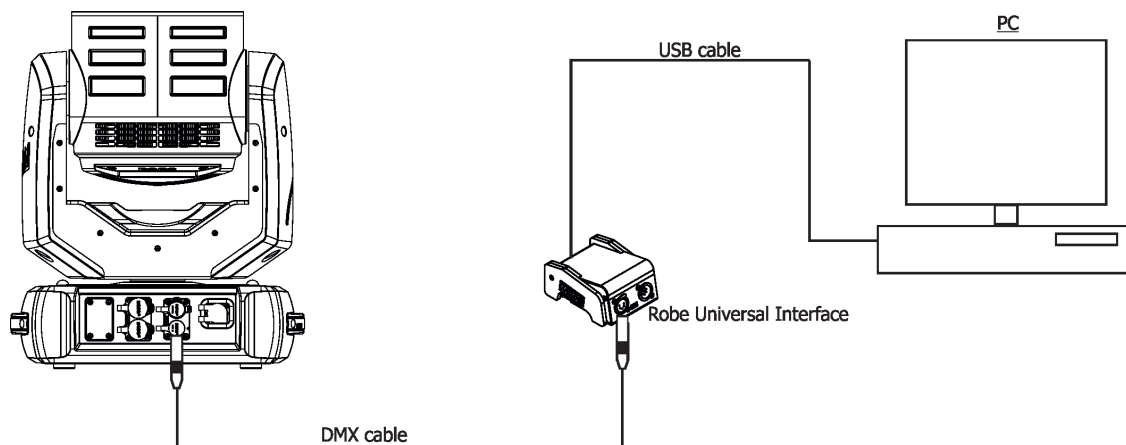

4. Switch the fixture to the update mode (Tab "Service" --> Update software).

Note: If you do not want to continue in the software update, you have to switch off and on the fixture to escape from the updating mode.

We recommend to cancel all running programs on your computer before starting the software uploader.

5. Double-click the software uploader file (e.g. DSU_RobiniBeam 350_18051835.exe) in the extracted files. The Software Uploader program will start running.

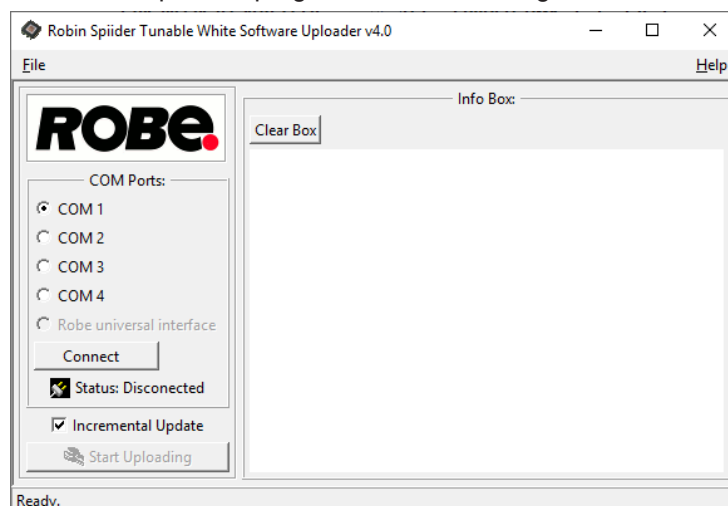

6. Select correct "COM " number if you use a Flash cable RS232/DMX or select "Robe Universal Interface 1 " if you use the Robe Universal Interface/Robe Universal Interface WTX and then click on the "Connect" button.
7. If the connection is OK, click the "Start Uploading" button to start software uploading. It will take several minutes to perform software update.
 If the option "Incremental Update" is not checked, all processors will be updated (including processors with the same software version).
 If you wish to update only processors with new version of software, check the "Incremental Update box".
 Avoid interrupting the process. Update status is being displayed in the "Info Box" window.
 When the update is finished, the line with the text "Fixture is successfully updated" will appear in this window.
 Note: After all processors updating, the fixture will be set to default values. If you use the Incremental update, setting the fixture to default values depends on type of updated processors.
 In case upload process is interrupted (e.g. power loss), the fixture stays in "Updating mode" and you will have to repeat the software update again.

Another way, how to update software in the fixtures (especially large installation of fixtures) is to use the ROBE Uploader. It is a software for automatized software update of Robe fixtures. It can take advantage of RDM support and Ethernet ports if present in the units.
 For more information please see <https://www.robe.cz/robe-uploader/>.

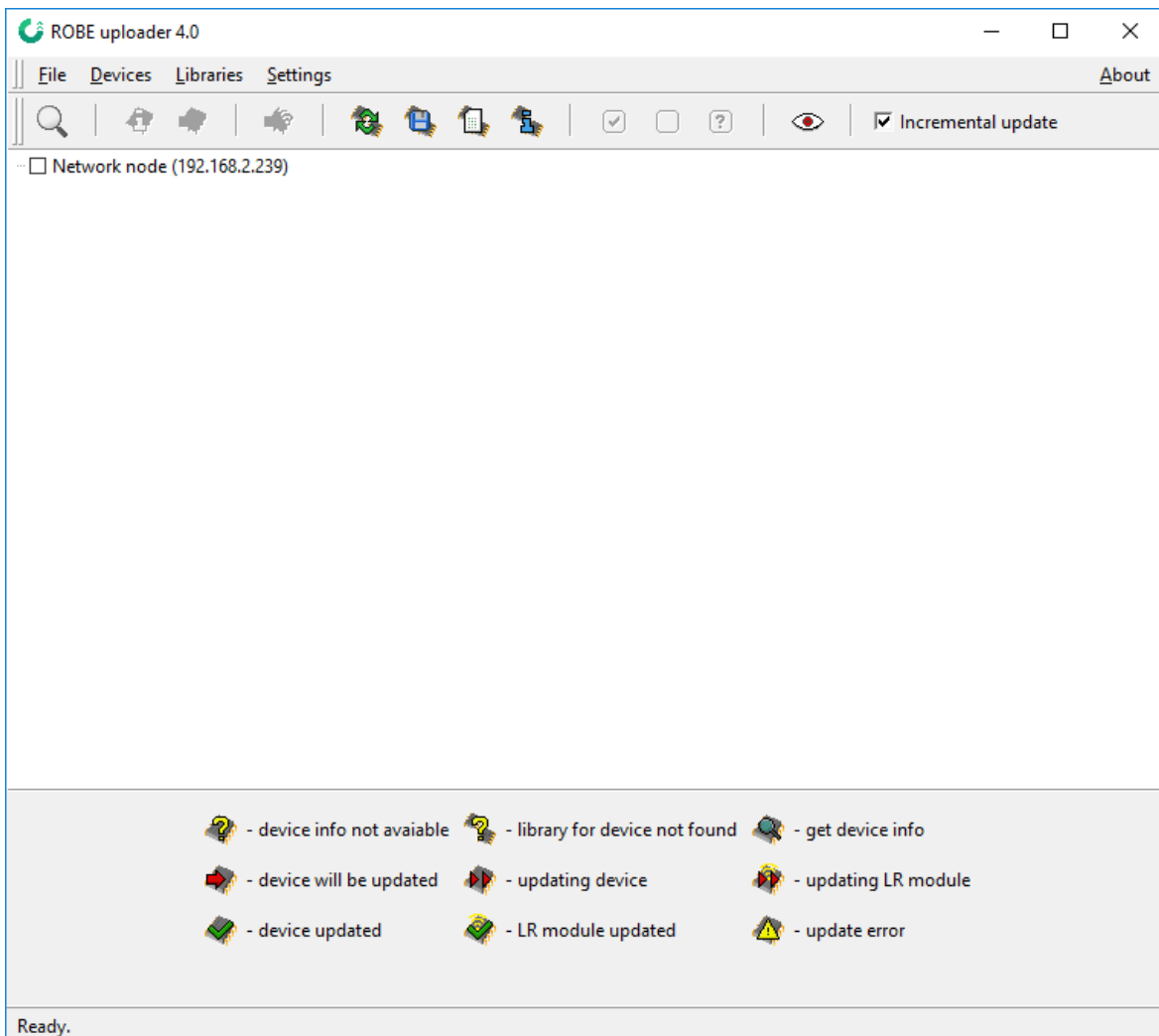

11. RDM

This fixture supports RDM operation. RDM (Remote Device Management) is a bi-directional communications protocol for use in DMX512 control systems, it is the new open standard for DMX512 device configuration and status monitoring.

The RDM protocol allows data packets to be inserted into a DMX512 data stream without adversely affecting existing non-RDM equipment. By using a special „Start Code,“ and by complying with the timing specifications for DMX512, the RDM protocol allows a console or dedicated RDM controller to send commands to and receive messages from specific moving lights.

RDM allows explicit commands to be sent to a device and responses to be received from it.

The list of commands for Robin iBeam 350 is the following.

Parameter ID	Discovery command	SET command	GET command
DISC_UNIQUE_BRANCH	*		
DISC_MUTE	*		
DISC_UN_MUTE	*		
DEVICE_INFO			*
SUPPORTED_PARAMETERS			*
SOFTWARE_VERSION_LABEL			*
DMX_START_ADDRESS		*	*
IDENTIFY_DEVICE		*	*
DEVICE_MODEL_DESCRIPTION			*
MANUFACTURER_LABEL			*
DEVICE_LABEL		*	*
SENSOR_DEFINITION			*
SENSOR_VALUE			*
DISPLAY_INVERT		*	*
DISPLAY_LEVEL		*	*
PAN_INVERT		*	*
TILT_INVERT		*	*
DEVICE_RESET		*	
DMX_PERSONALITY		*	*
DMX_PERSONALITY_DESCRIPTION			*
STATUS_MESSAGES			*
STATUS_ID_DESCRIPTION			*
DEVICE_HOURS ²			*
ROBE_DMX_INPUT		*	*
ROBE_WIRELESS_UNLINK		*	

²...Commands relative resetable values

RDM model ID for the Robin iBeam 350 is 0x0133.

12. NFC

The fixture supports NFC. Using the mobile phone application ROBE COM you can read and set the Robin iBeam 350 parameters (DMX address, IP address...etc.), get information about temperatures, operation hours, RDM identification etc.

The NFC point is situated on the front panel of fixture's base.



Download and install the ROBE COM from Google Play (for Android 5.0 and higher) or App Store (for iOS 12.0 and higher) to your mobile phone. Your mobile phone has to support NFC (Near-Field Communication).

Hold the mobile phone on the side of the fixture base, if NFC connection is OK, discovered fixture will appear on the screen, after touching the fixture name the following the following menu items will appear:

- DMX/RDM settings
- Ethernet settings
- Blackout settings
- Colour settings
- Display settings
- Standalone settings
- Pan/Tilt settings
- Other settings
- Software versions
- Device hours
- Device temperatures

Touch desired menu item to enter its submenu.

13. Error and information messages

Error in the fixture is signalled by the yellow warning icon at the bottom line of the screen:

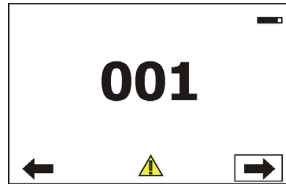

Press the [ESCAPE] button to display error messages.

List of error and information messages:

Temper.Sensor Error

The message informs you that the communication between the head temperature sensor and the main processor failed.

Tilt Error 1 (Tilt Error 2)

This message will appear after the reset of the fixture if the head's magnetic-indexing circuit malfunctions (sensor failed or magnet is missing) or the stepping motor is defective or its driving IC on the PCB. The head is not located in the default position after the reset.

Pan Error 1 (Pan Error 2)

This message will appear after the reset of the fixture if the yoke's magnetic-indexing circuit malfunctions (sensor failed or magnet is missing) or the stepping motor is defective or its driving IC on the PCB. The yoke is not located in the default position after the reset of the fixture.

Pan Error 3

There is some problem with pan/tilt feedback, pan control electronics has not got signal from pan sensor.

Zoom Error 1 (Zoom Error 2)

The messages will appear after the reset of the zoom module if the zoom module is not located in the default position.

EEprom Error

Hardware error of the EEprom.

Recharge The battery

The battery on the display board needs to be charged. Let the fixture on for cca 6 hrs.

Battery faulty. Replace it.

The battery on the display board is exhausted and should be replaced immediately.

Pan/Tilt EMS Cal. Error

The EMS system is not calibrated.

Pan/Tilt EMS Error

Control electronics cannot communicate with the EMS system.

LEDs Curent Cal. Missing

LEDs current calibration was not done. Go to the tab Service and run the item LEDs Current Calibration. Note: Calibration of LEDs current can be also run by means of the RDM manager ver. 1.0.12 and higher (LED Driver -->Start Current Calibration).

Too Much Humidity in Device

To remove the message, reset the bar chart Max.Wet in the menu RAINS Status (tab Information) and check the silica gel desiccant in the fixture arm.

Valve Seal Error

The valve in fixture head or coil in the valve is defective or there is a connection problem between the valve and head, check cable connector at valve.

14. Cleaning

Regular cleaning will not only ensure the maximum light output, but will also allow the fixture to function reliably throughout its life.

The frequency of cleaning depends on the environment in which the fixture operates: damp, smoky or particularly dirty environments can cause greater accumulation of dirt on the fixture housing.

The front glass cover of the head will require cleaning on a monthly basis.

A soft lint-free cloth dampened with a solution of water and a mild detergent is recommended, under no circumstances should alcohol, solvents or abrasives be used!

DANGER !

Always disconnect the fixture from mains before starting any cleaning or maintenance work.

**Important! Never use alcohols (ethanol, methanol, isopropyl alcohol), acetone and another aggressive solvents for cleaning the lens array.
Do not immerse lenses in liquid (e.g. water) during cleaning.**

Recommended steps for cleaning the front lens array:

1. Use low-pressure compressed air to remove coarse dust from lenses.
2. Use distilled water with weak detergent solution and lint-free small cloth for further cleaning of lenses.
3. Use an antistatic, alcohol-free screen cleaner (we recommend the Lyreco Screen Cleaner) and polish lenses until they are dry.
4. Check the lenses are dry before reapplying power.

Potential stains on fixture covers caused by hard water (water that has high mineral content) can be effectively removed by means of non-abrasive descaler (e.g. EverStar descaler).

Note: potential foggy lens array does not influence function of the fixture and does not subject to complaint

15. Maintenance

In order to ensure the fixture remains in good condition and does not fail prematurely, we recommend regular maintenance.

The following points have to be considered during fixture inspection:

- All outside covers and screws should be checked for damages, scratches or corrosion.
- All connectors and its rubber caps should be checked for damages or sediments.
- All screws and fasteners has to be securely tightened. Check for any deformation on the housing and rigging points. Damaged rigging points or unsecured rigging could cause the fixture to fall and seriously injure people.
- Electric power supply cable must not show any damage or material fatigue.
- Fans and heatsink should be checked for sediments or dirt/debris accumulation.

User can do the following operations:

- main fuse replacement
- battery replacement
- silica gel desiccant replacement

Another maintenance, cleaning and service operations should be carried out by trained technicians only.

If you need any spare parts, please order genuine parts from your local Robe distributor.

Fixture metal covers are made of material resistant to corrosion, potential damages of covers (like scratches, abrasions) are only appearance defects and will not cause corrosion of covers.

To repair small damages of fixture metal covers (e.g. scratches), you can use a paint intended for non-rusting metal surfaces (like aluminium, copper...). The paint can be applied to surface by means of a small brush or by spraying.

Use the paint with the same colour and sheen as has your cover. The paint can perform as undercoat or top-coat, it doesn't matter.

Do not remove fixture covers in smoky or particularly dirty environment (e.g. with fog machines).

IMPORTANT: in case of service intervention, the base cover should be uncovered as short time as possible (about 1-2 hours depending on air humidity) otherwise silica gel in the small boxes in the fixture base may become damp.

If you have removed base cover and you need to interrupt your service work for longer time (hours, days), we recommend to place base cover on the base and fasten it provisionally by means of two screws, next possibility is unscrewing small boxes with silica gel from the base and put them to a sealed container with limited access of air (e.g. sealed plastic bag).

Checking plastic parts of the fixture.

The plastic parts of the fixture should be checked for damages and beginning cracks at least every two months. If hint of a crack is found on some plastic part, do not use the fixture until the damaged part will be replaced. Cracks or another damages of the plastic parts can be caused by the fixture transportation or manipulation and also aging process may influence plastic materials.

This checking is necessary for both fixed installations and preparing fixtures for renting. Any free moving parts inside of the fixture head, cracked plastic or any plastic part not sitting properly in place need to be immediately replaced.

Replacing the fuse.

Before replacing the fuse, disconnect the fixture from mains.

1. Remove the cover (1) of the battery and fuse compartment by unscrewing four screws (4) with sealing rings (3).
2. Using a flat-blade screwdriver, unscrew (anti-clockwise) the fuse holder from the rear panel of the base.
3. Remove the blown fuse from the fuse holder.
4. Place a good fuse (only the same type and rating) into the fuse holder and screw the fuse holder back.
5. Place the cover (1) with gasket (4) back on the rear panel of the fixture and fasten it by means of the four screws (2) with sealing rings (3). Tighten screws crosswise in two steps:
Step 1 - use tightening torque 0.5Nm (pre-tightening)
Step 2 - use tightening torque 2.5Nm (final tightening)

Replacing the battery.

Before replacing the battery, disconnect the fixture from mains.

1. Remove the cover (1) of the battery and fuse compartment by unscrewing four screws (2) with sealing rings (3).
2. Loosen (anti-clockwise) the battery holder cap.
3. Remove the exhausted battery from the battery holder.
4. Place a new battery (only the same type) into the battery holder (Negative (-) inside, Plus (+) outside).
5. Place and tighten the battery holder cap back.
6. Place the cover (1) with gasket (4) back on the rear panel of the fixture and fasten it by means of the four screws (2) with sealing rings (3). Tighten screws crosswise in two steps:
Step 1 - use tightening torque 0.5Nm (pre-tightening)
Step 2- use tightening torque 2.5Nm (final tightening)

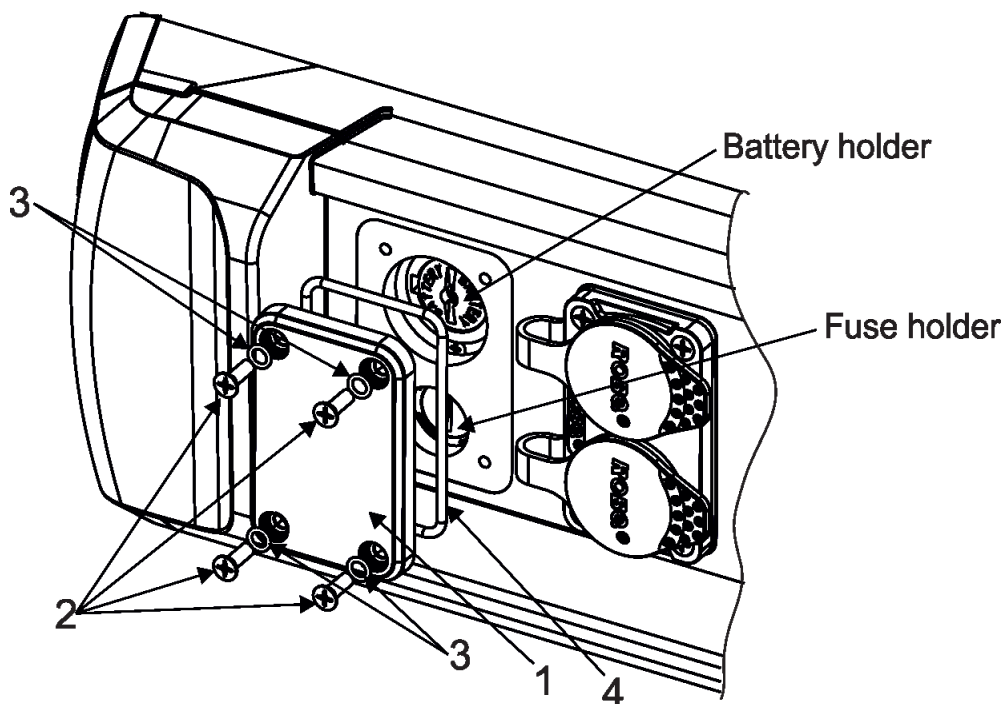

15.1 Torques for watertight covers

Keep values of torques as stated on pictures below otherwise leakage issues can occur.

Run the procedure Pressure Test (Service --> Pressure Test) after replacing any watertight cover!

Bottom base cover

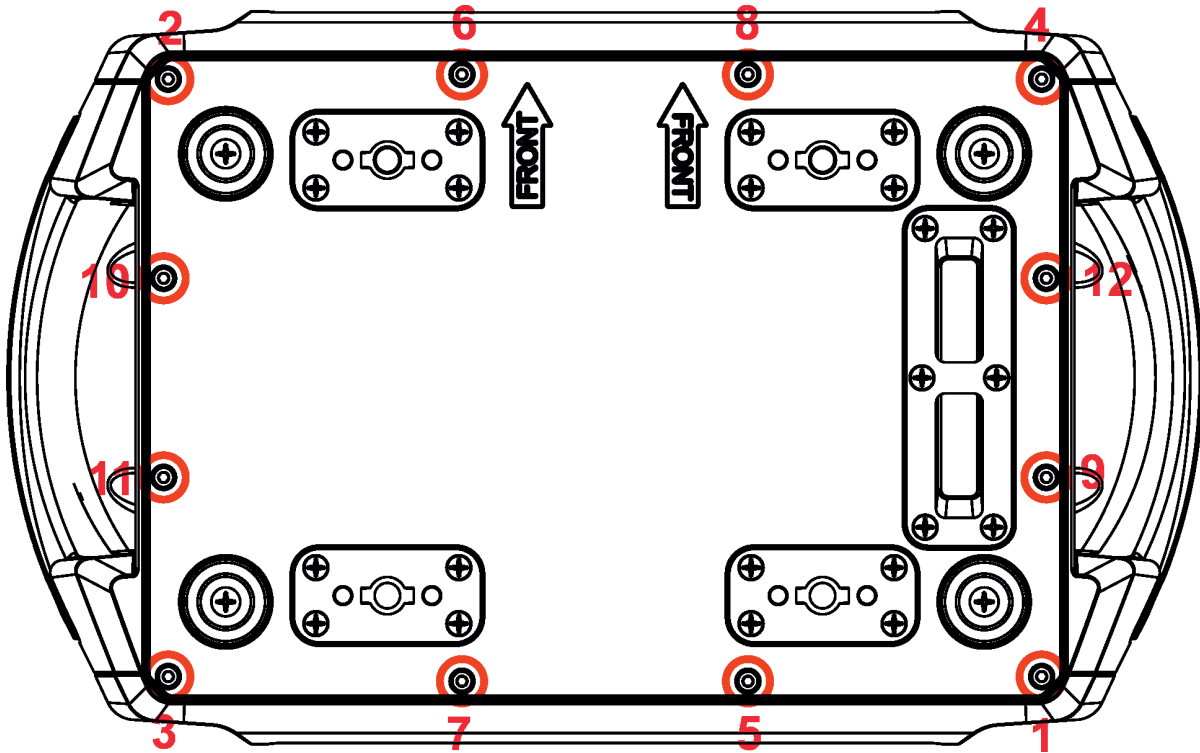

Screws must be tightened in the order 1-->12

12 x hex socket head screw M4x14
12x Spring washer
Tightening torque: 2.2-2.5 Nm*

* Tighten all screws in two steps:
Step 1 - use tightening torque 0.5Nm (pre-tightening)
Step 2- use tightening torque 2.2-2.5Nm (final tightening)

Carefully check the gasket for signs of deformities or damages and if it is correctly placed before screwing the bottom cover back. The gasket is part of base.
Do not forget to connect grounding wire between chassis and the base cover.

Yoke cover

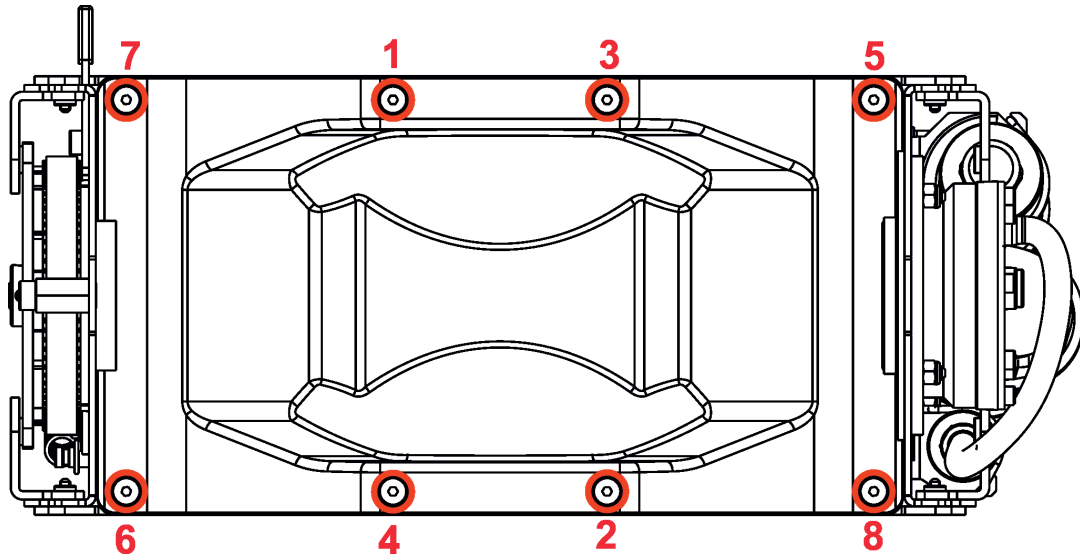

Screws must be tightened
in the order 1-->8

* Tighten all screws in two steps:
Step 1 - use tightening torque 0.5Nm
(pre-tightening)
Step 2- use tightening torque 2.2-2.4Nm
(final tightening)

8 x hex socket head screw M4x12
8 x star washer
Tightening torque: 2.2-2.4 Nm*

Carefully check the gasket for signs of deformities or damages and if it is correctly placed before screwing the yoke cover back. The gasket is part of chassis.

Do not forget to connect grounding wire between chassis and yoke cover.

Head flange

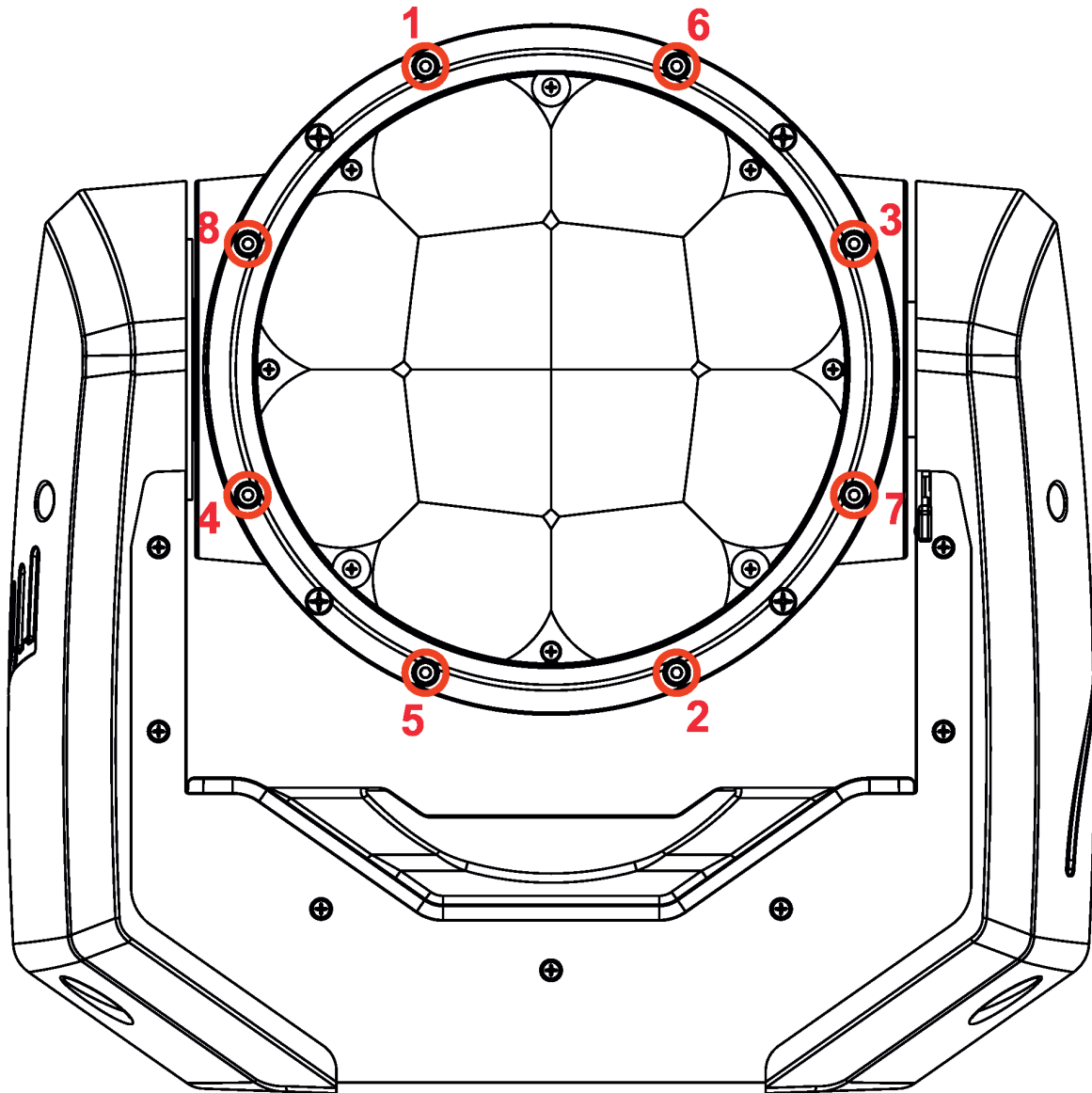

Screws must be tightened
in the order 1-->8.

8 x hex socket head screw M4x8
Tightening torque: 2-2.4 Nm*

* Tighten all screws in two steps:
Step 1 - use tightening torque 0.5Nm
(pre-tightening)
Step 2- use tightening torque 2-2.4Nm
(final tightening)

Carefully check the gasket for signs of deformities or damages and if it is correctly placed on the glass cover before screwing the head flange back.

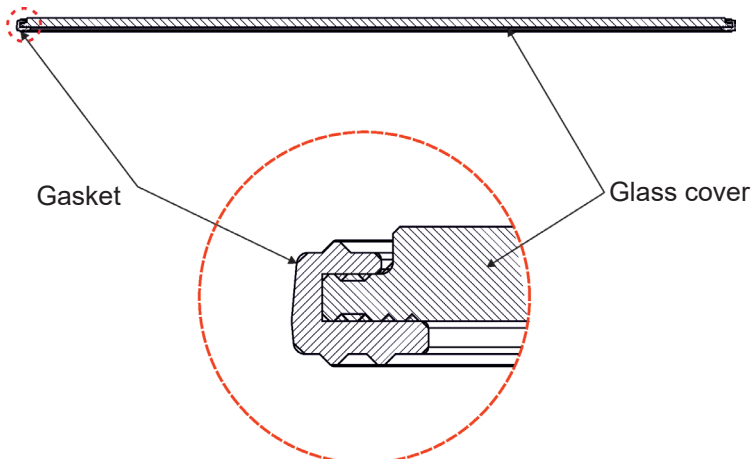

Positions of watertight covers

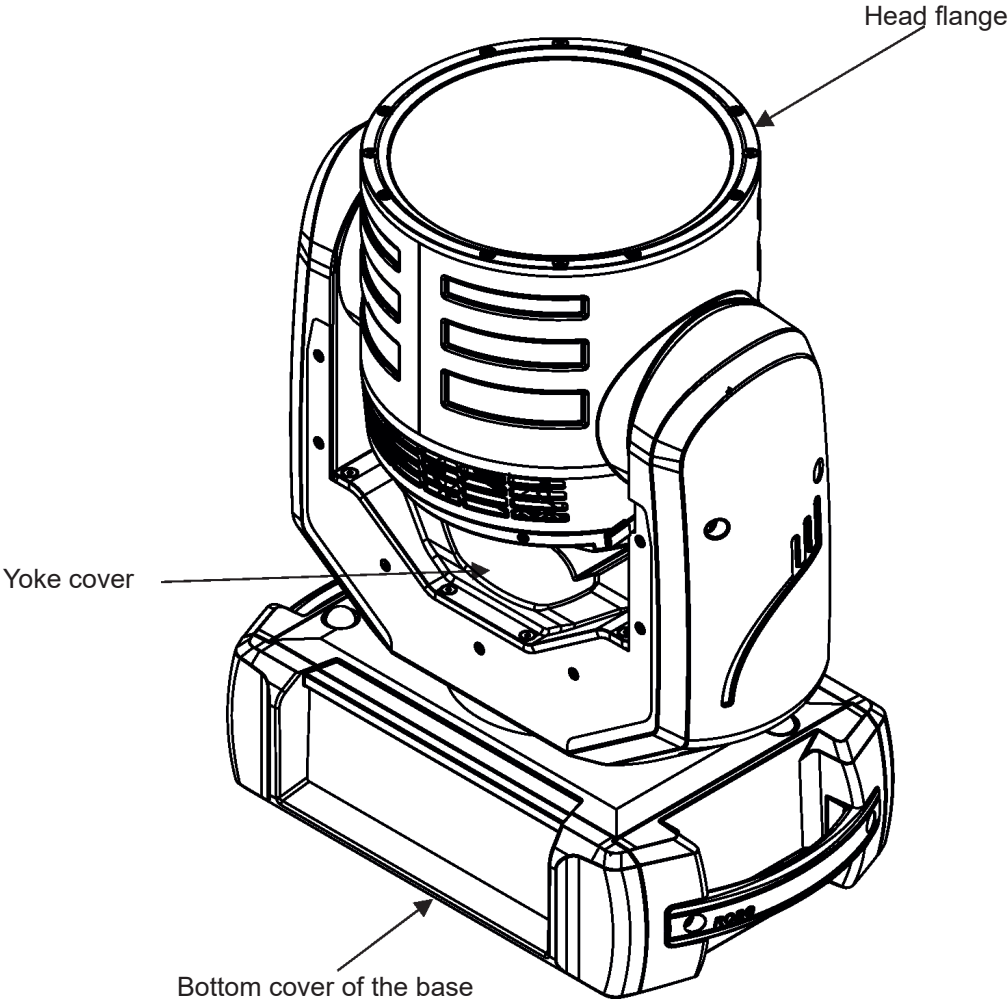

15.2 Torques of Pan/Tilt motors screws

Tilt motor

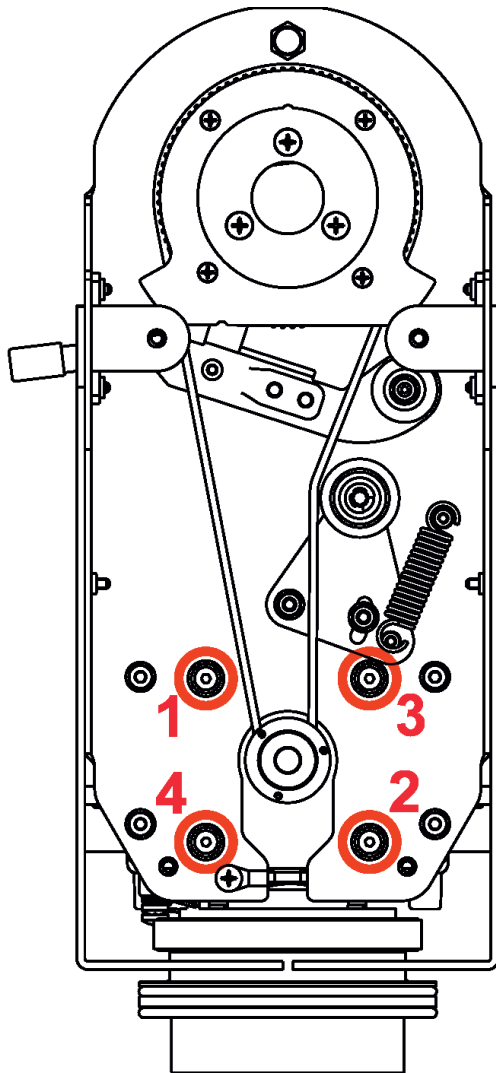

4 x hex socket head screw M4x18 (stainless) with washer

Screws must be tightened in the order 1-->4,

Pan motor

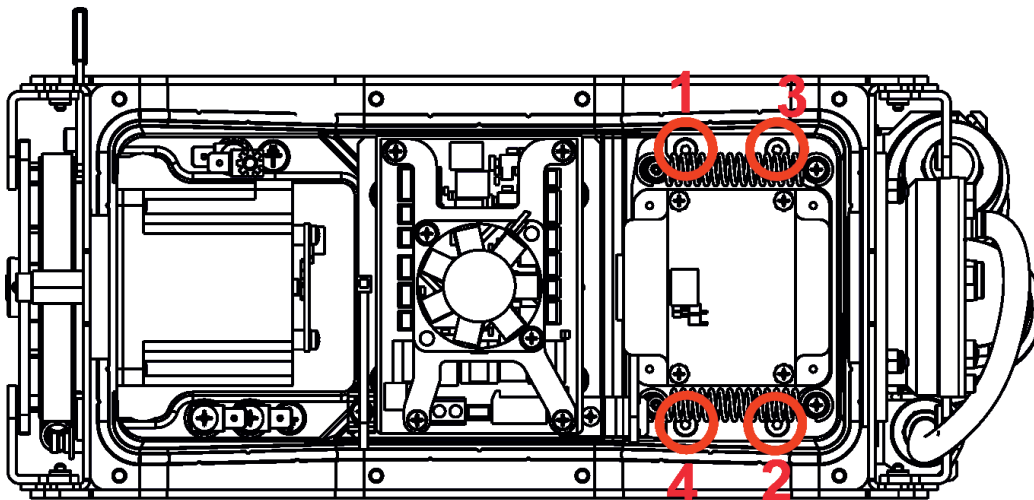

4 x hex socket head screw M4x12 (stainless)

Screws must be tightened in the order 1-->4.

15.3 Checking and replacing the silica gel desiccants

The silica gel desiccants are used for humidity indication in the fixture. Dry silica gel has an orange colour, if it is saturated with water, its colour changes to dark grey. If most of silica gel changed colour to dark grey, it has to be replaced.

***Unplug the fixture from mains before checking/replacing silica gel desiccant!
Do not check/replace silica gel desiccant in a damp environment (e.g. rain, snowfall)!***

***Spare desiccants from factory are packaged in a protective foil. Take desiccants out of the protective foil immediately before replacing them in the fixture!
Silica gel may become damp if it is exposed to wet air for longer time.***

Silica gel is not under warranty

Desiccants are placed in the fixture in the following places:

fixture base - 2 x small box with silica gel on the cover of base

fixture arm without tilt lock - 1 x tube with silica gel

Fixture base

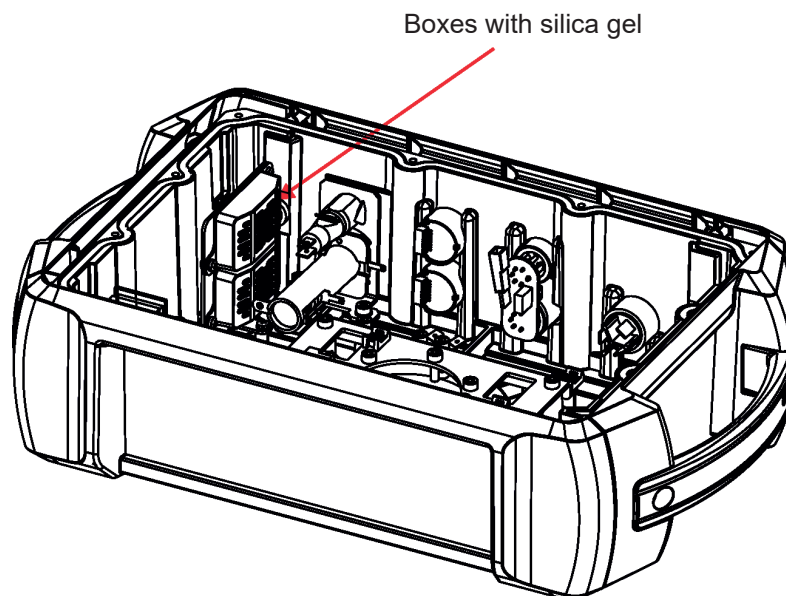

Each silica gel box is fastened on the cover by means of two screws.

The silica gel desiccants in the fixture base should be checked (or alternatively replaced) at removing bottom cover e.g. at service intervention.

After checking/replacing boxes with silica gel do not forget to connect grounding wire between chassis and base cover at placing the cover back.

After checking/replacing boxes with silica gel, run the procedure Pressure Test (Service -->Pressure Test).

If the pressure test is not OK, check if all screws of base cover are correctly tightened and run the test again.

Examples:

Dry silica gel

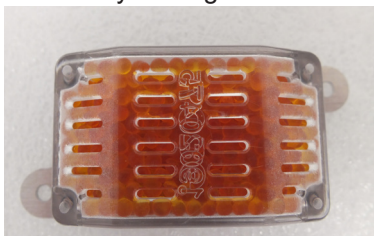

Silica gel saturated with water

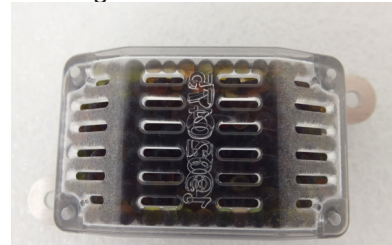

Fixture arm

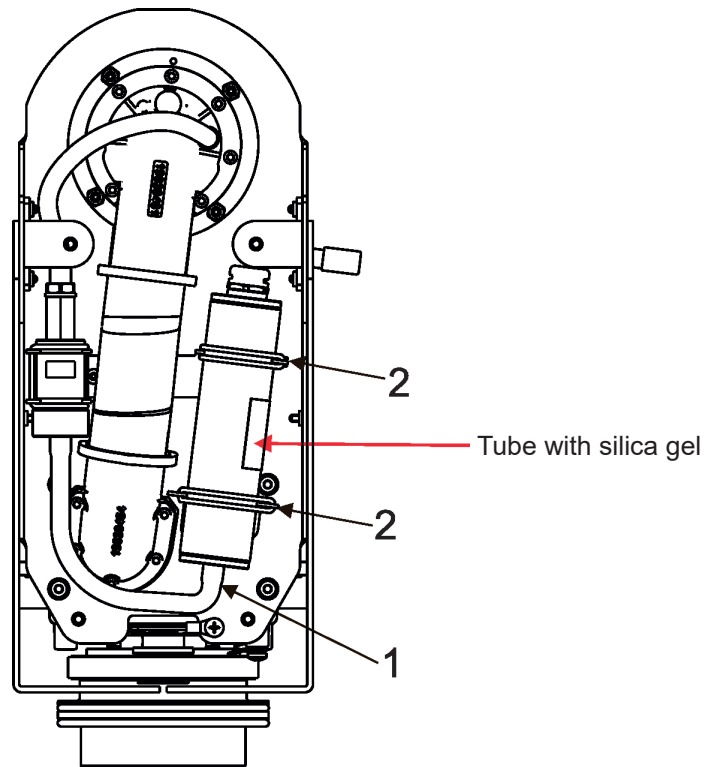

To change the tube with silica gel:

1. Disconnect the fixture from mains.
 2. Remove the arm cover.
 3. Disconnect the hosepipe(s) (1) from the tube with silica gel.
 4. Stick out the rubber rings (2) and remove the tube with silica gel.
 5. Insert the new tube with silica gel and secure it by means of the rubber rings (2).
 6. Connect the hosepipe(s) (1) to the tube with silica gel.
 7. Screw the arm cover back.
 8. **After connecting the fixture to mains, reset the MAX WET chart (tab Information-->RAINS Status) and run the procedure Pressure Test (tab Service -->Pressure Test).**
- If the pressure test failed, check if hose-pipes are correctly put on the tubes with silica gel.

Example of dry silica gel and silica gel saturated with water:

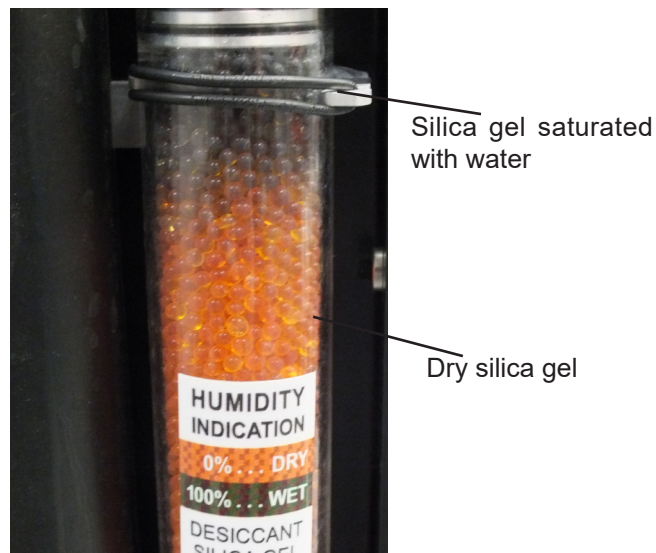

State of desiccant in the tube can be checked:

- visually by unscrewing the arm cover
- from fixture display (tab Information, option RAINS Status):

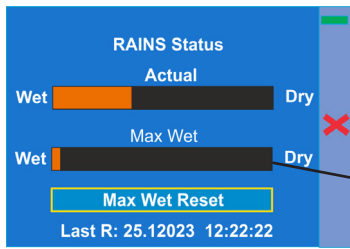

- remotely by means of the Robe Ethernet Access Portal (REAP):

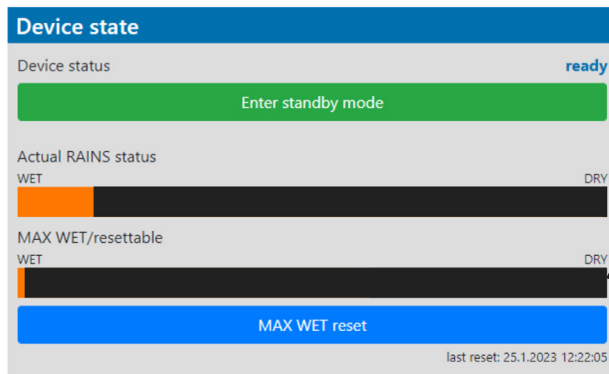

The chart MAX WET is decisive for replacing the desiccant in the tube in the fixture arm.

If the chart has changed to black colour, desiccant in tube has to be replaced.

It is not necessary to replace silica gels desiccants in plastic boxes in the fixture base. These desiccants should be checked (and replaced if it is needed) at removing base covers e.g. at some service intervention.

In case that silica gel in the tube is fully saturated with water, the warning message "**Too Much Humidity in Device**" will appear on the fixture display (yellow warning icon) and also in the Robe Ethernet Access Portal (Logs screen).

Example



16. Robe Ethernet Access Portal (REAP)

Before running the REAP, your computer needs to be connected to the fixture (s) through the means of Ethernet wired network and a network switch. The computer needs to have configured network settings in order to be able to communicate with the fixture(s) through the network. The Ethernet network connection (Local LAN) typically needs to be set to 2.x.x.x address, the computer IP address has to be set to 2.x.x.x (for example 2.247.136.20) with netmask 255.0.0.0. On the fixture make sure to use the default 2.x.x.x IP address as provided. You do not need change any IP settings on the fixture, There is no need to set the fixture into Art-Net mode.

Type the IP address of the iBeam 350 to your web browser, e.g. <http://2.247.220.15>, enter the user name: **robe** and the password: **2479**, the **Status screen** of the iBeam 350 will appear.

This screen gives you a fast overview of fixture settings and environment in the fixture. The icon  allows you to change some values in a corresponding table.

Example for DMX/RDM settings:

Note.

The background colour of the top row of the Status screen with the name and RDM label of the fixture denotes state of the fixture:

	fixture is ready for operation
	fixture does not communicate with computer
	fixture with error message(s)

The table "Device state" gives you information about fixture and environment in the fixture.

Device status: **ready** - all fixture resets successfully passed and the fixture is ready for operation.

initialization - fixture is waiting for fixture reset

heating - fixture is waiting for reaching operating temperature of the fixture inside (temperature in the fixture is below 0°C).

standby - the fixture is in standby mode

standby/heating - the fixture is in standby mode and inside of the fixture is heated

The bar chart **Actual RAINS status** informs you about current humidity in the fixture. The bar chart changes depending on humidity, temperature and pressure in the fixture. The bar chart depends on current conditions in the fixture and can be different at start of fixture operation, after 10 minutes of its operating, after closing fixture dimmer etc.

RAINS (Robe Automatic Ingress Neutralization System) manages humidity, temperature and pressure control using an active monitoring system to automatically remove any moisture detected within the fixture and provides permanent monitoring to ensure peak performance of the fixture.

The bar chart **MAX WET/resettable** informs you about maximum humidity achieved in the fixture since the chart was last reset. The bar chart also informs you about saturation of silica gel desiccant in tube in the fixture arm with water and is deciding indicator for its checking and replacement.

The blue button **MAX WET reset** resets the bar chart MAX WET/resettable. Date and time of last reset is displayed below this button.

Silica gel desiccant in the fixture arm

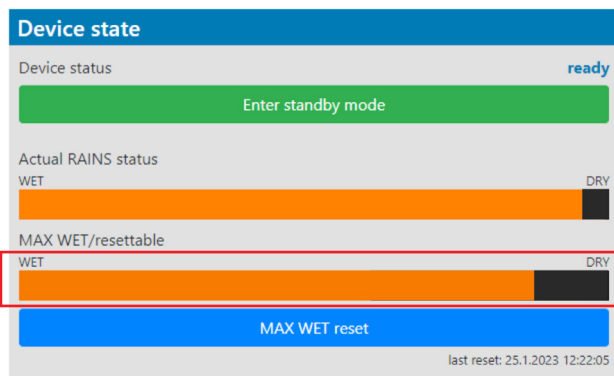

Examples of the table "Device state":

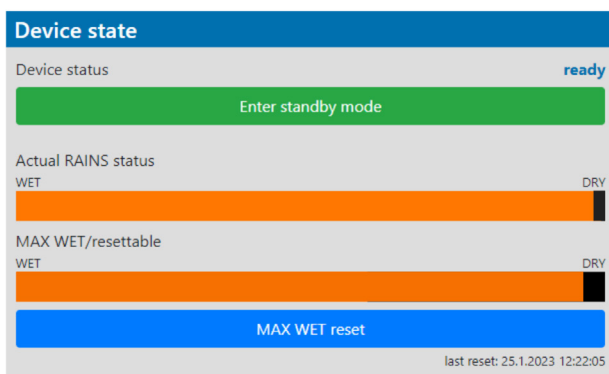

Dry desiccants

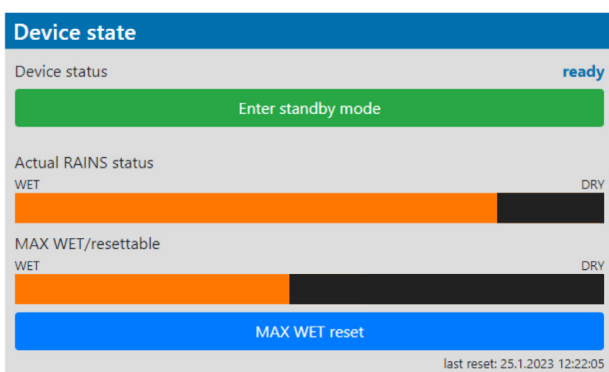

Desiccants partially saturated with water

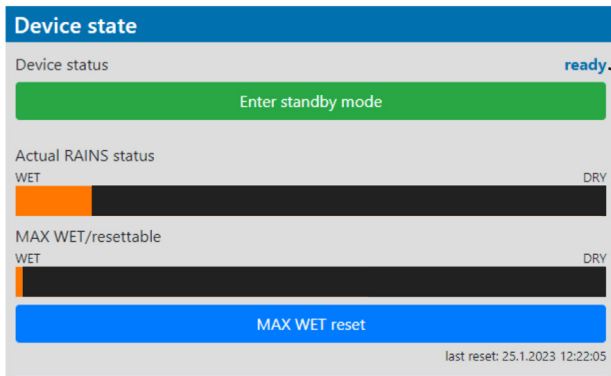

Device status **ready** means, that all fixture resets are OK and the fixture is ready for operation. It does not assess state of desiccants or result of pressure test!

Desiccants fully saturated with water

Silica gel desiccant in tube in the fixture arm should be replaced.

After replacing it, reset MAX WET resettable bar chart.

It is not necessary to replace silica gels desiccants in plastic boxes in the fixture and base. These desiccants should be checked (and replaced if it is needed) at removing base cover, e.g. at some service intervention.

The option **Enter standby mode** allows you to switch the fixture to Standby mode.

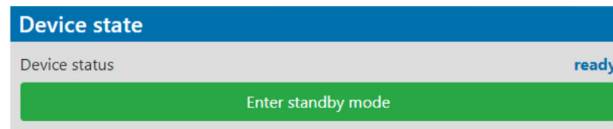

Note: Standby mode helps conserve power when a fixture is not in use, without fully powering it off. In the Standby mode, all fixture motors and fans are deactivated and light output is closed. For more information about Standby mode please see the chapter Standby mode.

The option **Escape standby mode** allows you to switch the fixture to standard operating mode.

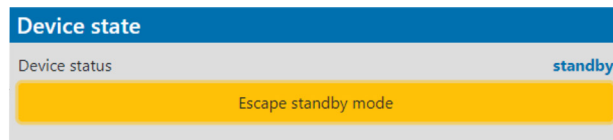

The **Personality** screen allows you to set fixture behaviour and run a pressure test.

The icon  allows you to change values in a corresponding table.

Example for Pan/Tilt settings:

The table "Pressure test " with green button **Start test** allows you to run a procedure which checks IP65 integrity of the fixture. The fixture has to be connected to mains and the head temperature (at pressure sensor) cannot be higher than 55°C. The pressure test lasts about 5 minutes and can be run at earliest 10 minutes after closing light output (shutter closed) of the fixture. The pressure test can be repeated at earliest 2 minutes after last pressure test.

Examples of pressure test messages:

Pressure test is 10 minutes delayed due to fixture cooling

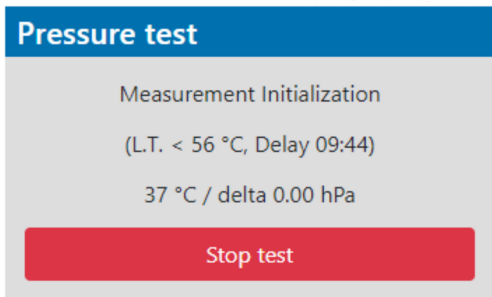

Pressure test is running

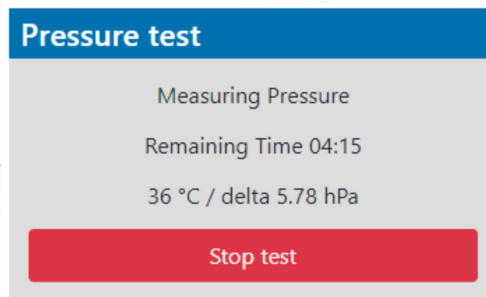

Pressure test passed

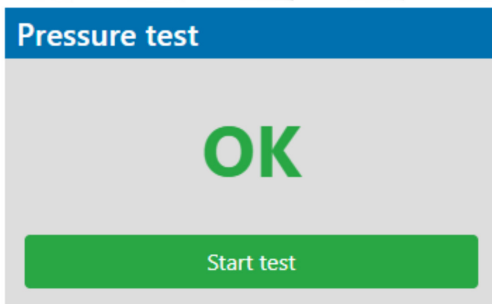

Pressure test failed

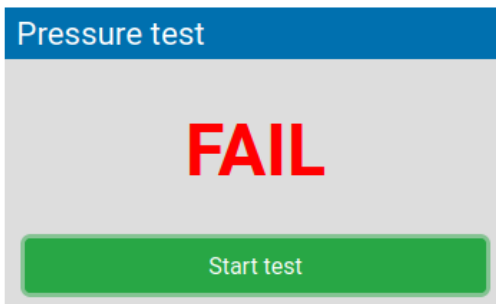

The **Logs screen** displays operating information of the fixture which have been saved.

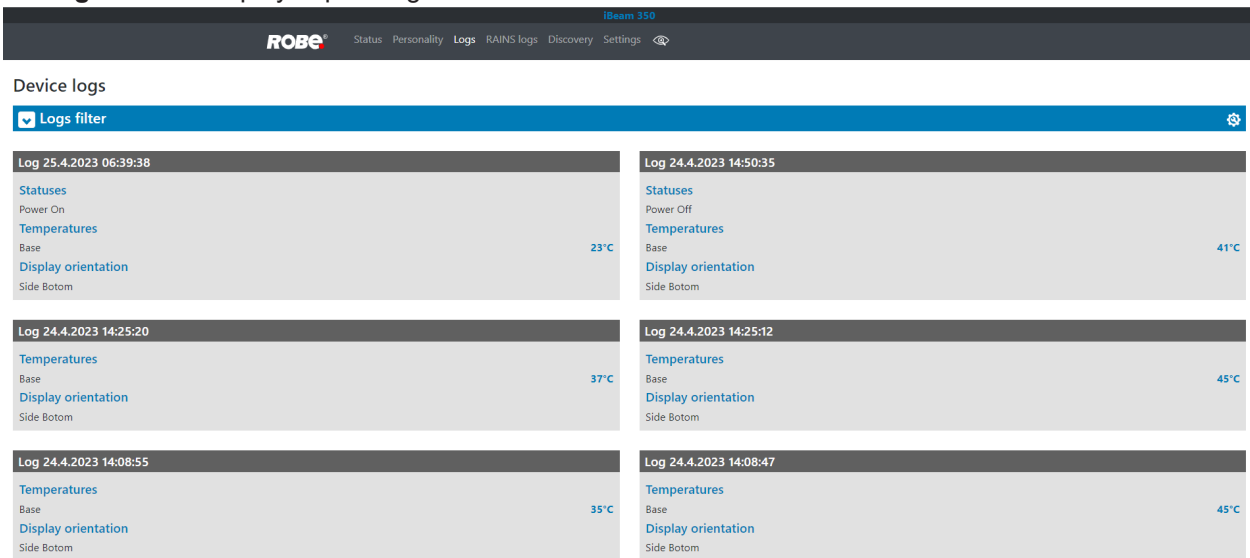

The icon  offers you two options:

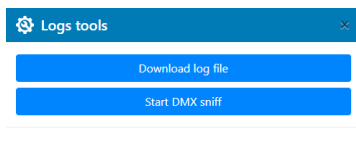

"Download log file" - the option allows you to download the log file to computer, name of the log file is: file-abcd.log, where abcd is a fixture ID (e.g. file-015e.log).

"Start DMX sniff" - the option starts saving coming DMX values to the file, the file name is DMX_sniffer.log).

The option **Logs filter** allows you to select desired group of recorded errors and recorded operating values.

Expanded menu **Logs filter**

The screenshot shows the 'Device logs' section of the ROBE iBeam 350 interface. A 'Logs filter' menu is expanded, showing various error categories and their sub-options. The filter menu includes:

- Mechanical errors** (all must pass): Pan error, Tilt error, Zoom error, Leds error.
- System errors** (all must pass): Fans failure, Too much humidity in device, Powerdown mode, Temperature sensor error, Eeprom error, Recharge the battery, Battery faulty, replace it.
- Statuses** (all must pass): Power on, Power off.
- Temperatures** (all must pass): Base (23°C).

Additional filter options include 'Start date/time' (Date: dd.mm.yyyy, Time: --:--:--), 'Sorting, filter pass' (Sorting: descending, Filter pass: single groups), and buttons for 'Apply filter' and 'Clear filter'.

Below the filter menu, two log entries are displayed:

- Log 25.4.2023 06:39:38**: Statuses (Power On), Temperatures (Base: 23°C), Display orientation (Side Botom).
- Log 24.4.2023 14:50:35**: Statuses (Power Off), Temperatures (Base: 41°C), Display orientation (Side Botom).

If the option "all must pass" is checked, only logs which contain all selected errors will be displayed.

Menu "Sorting filter pass" --> option "single groups" means that logs which contain at least one selected error will be displayed.

Menu "Sorting, filter pass" option "all groups" means that logs which contain all selected error will be displayed.

The **RAINS Logs screen** offers you a list of physical values recorded by sensors inside the head.

The screenshot shows the 'RAINS logs' section of the ROBE iBeam 350 interface. The 'Sensors' tab is active, showing 'Pressure measurements'. A 'Logs filter' menu is visible at the top. Below it, a table displays recorded data for Temperature [°C], Relative humidity [%], and Pressure [hPa] over time.

Date / Time	Temperature [°C]	Relative humidity [%]	Pressure [hPa]
29.5.2023 13:26:41	37	20.0	984
29.5.2023 13:25:09	39	20.5	984
29.5.2023 13:24:53	38	21.0	984
29.5.2023 13:24:41	37	21.0	984
29.5.2023 13:24:29	36	21.5	984
29.5.2023 13:18:50	35	21.0	984
29.5.2023 13:14:36	34	21.0	984
29.5.2023 13:12:38	33	21.5	984
29.5.2023 13:11:28	32	22.5	984
29.5.2023 13:10:46	31	23.5	984

You can select range of temperature, humidity and pressure in desired time interval.

Date / Time	Temperature [°C]	Relative humidity [%]	Pressure [hPa]
29.5.2023 13:26:41	37	20.0	984
29.5.2023 13:25:09	39	20.5	984
29.5.2023 13:24:53	38	21.0	984
29.5.2023 13:24:41	37	21.0	984
29.5.2023 13:24:29	36	21.5	984
29.5.2023 13:18:50	35	21.0	984
29.5.2023 13:14:36	34	21.0	984
29.5.2023 13:12:38	33	21.5	984
29.5.2023 13:11:28	32	22.5	984
29.5.2023 13:10:46	31	23.5	984

Tab Pressure measurements shows history of pressure tests.

Date / Time	Temperature [°C]	Relative humidity [%]	Pressure [hPa]	Pressure difference [hPa]	Duration [ms]	Result
11.1.2023 14:59:17	47	8.5	991	7.03	03:26	OK
10.1.2023 09:45:47	27	11.0	988	7.28	02:32	OK



If you have two and more fixtures, the **Discovery** screen allows you to show all connected fixtures in network. Click on the blue button **Discover** and fixtures connected in the network will be displayed.

Device	DMX address	DMX preset	RDM UID	IP address	RAINs (max wet)	Device status
iBeam 350	1	Mode 1 (22 channels)	52:53:01:33:00:0f	2.247.220.15		active
iForte - iForte 3	1	Mode 1 (54 channels)	52:53:01:2c:00:1a	2.247.136.26		active
iSpider	1	Mode 1 (49 channels)	52:53:01:1c:00:0e	2.246.236.14		active

The background colour in the device row denotes state of the fixture:

- indicates "server fixture"(fixture of which IP address you have written to your WEB browser).
- indicates fixture ready for operation.
- indicates fixture which does not communicate with computer or "server fixture".
- indicates fixture with error messages.





If the option Move devices with warning to top is checked, fixtures with some error will be displayed on the top of fixture list.

The option Columns selection allows you to check desired items which will be displayed in columns. Max. 6 items can be selected. After checking desired items, click on the blue button Apply selection to activate selection. Icons   allows you to order values in the column in descending or ascending order.

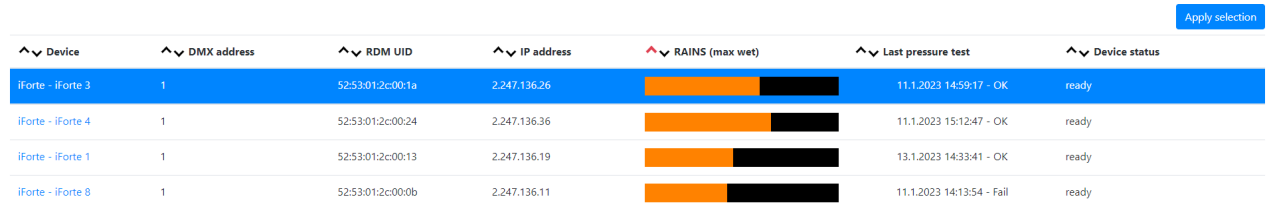
Note: The values of the fixture in the first blue row ("server fixture") will not be included into ordering.

Example.



Device	DMX address	RDM UID	IP address	RAINS (max wet)	Last pressure test	Device status
iForte - iForte 3	1	52:53:01:2c:00:1a	2.247.136.26		11.1.2023 14:59:17 - OK	ready
iForte - iForte 4	1	52:53:01:2c:00:24	2.247.136.36		11.1.2023 15:12:47 - OK	ready
iForte - iForte 1	1	52:53:01:2c:00:13	2.247.136.19		13.1.2023 14:33:41 - OK	ready
iForte - iForte 8	1	52:53:01:2c:00:0b	2.247.136.11		11.1.2023 14:13:54 - Fail	ready

Item **ready** in the column Device status does not assess state of desiccants or result of pressure test!

The **screen Settings** allows you to change password to REAP.

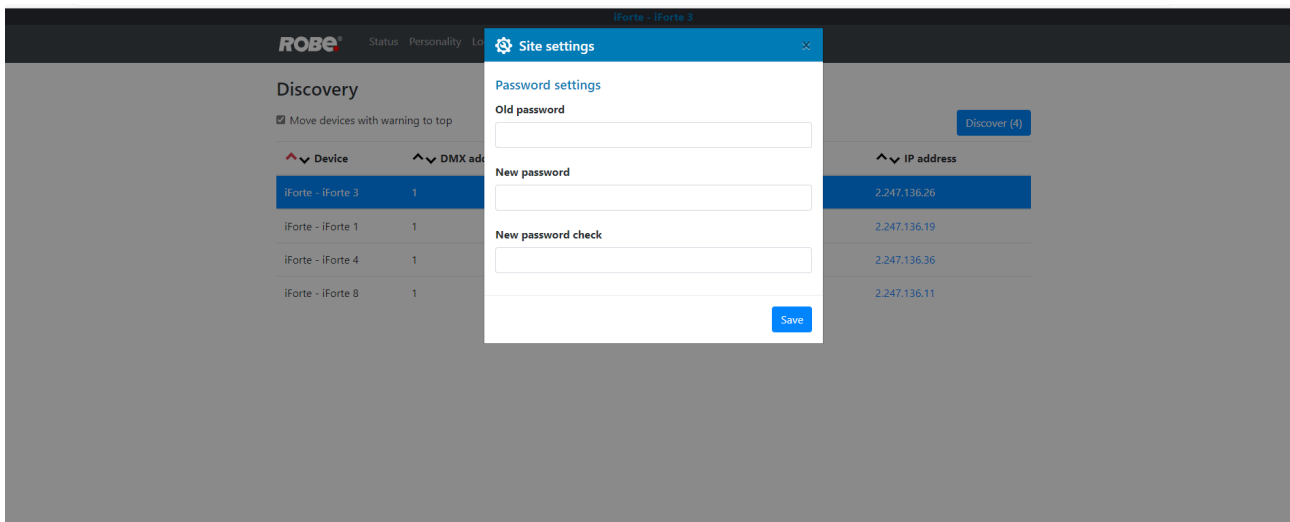

The icon  serves for identification of the fixture in a group of fixtures. After clicking on the icon, the fixture's head will start to move.

17. Technical Specifications

Electrical

Power supply: electronic auto-ranging
Input voltage range: 100-240V, 50-60Hz
Fuse: T 8A
Max. power consumption: 460W (power factor 0.95)

Source

Light source type: 12 RGBW multichips
LED life expectancy: min. 50.000 hours
Typical lumen maintenance: : L70/B50 @ 50.000 hours

Optical System

Robe's proprietary optical design
Zoom range: 3.8° - 52°

Virtual colour wheel

66 pre-programmed colours
Rainbow effect with in both directions with variable speed

CTO

Variable CTO 2700K-8000K
Pre-programmed whites 2.700K, 3.200K, 4.200K, 5.600K and 8.000K
Halogen lamp effect at whites 2700K-4200K

Strobe

Strobe effect with variable speed (0.3 - 20Hz)
Random strobe pulse-effect with variable speed
Opening/closing pulse effect with variable speed

Dimmer

Smooth dimmer from 0 - 100 %

Pan/Tilt

Max. pan movement range: 540° or 450°(switchable)
Max. tilt movement range: 228°
16 bit movement resolution
Automatic Pan/Tilt position correction
Remotely controllable speed of pan/tilt movement for easy programming

Control

Graphic touch screen for fixture setting and addressing
Gravitation sensor for auto screen positioning
Battery backup of the touch screen
Readout fixture usage, receiving DMX values, temperatures, etc
Built-in demo sequences
Stand-alone operation
3 user editable programs, each up to 40 steps
Supported protocols: USITT DMX 512, RDM, ArtNet, MANet, MANet2, sACN
Support of RDM (Remote Device Management)
3 DMX modes (22, 16, 24 control channels)

Wireless DMX/RDM module (type RW 001)

Supported protocols: full RDM support, CRMX , W-DMX™ G2, G3,G4 and G4S
Operational frequency range: 2402-2480 MHz
Output power: 100 mW
Receiver sensitivity (0.1% BER): -93 dBm
Crystal Clock Frequency : 16.0 MHz

Max. number of fixtures in Ethernet IN/Out line

8

Battery

Size: AA (R6)
Type: IFR 1450, 600mA/3.2V

Connection

DMX data in/out: IP65 Locking 5-pin XLR connectors Seetronic
Power : IP65 power conector Seetronic
Ethernet IN/Out: IP65 RJ45 connectors Seetronic

Connection (POI version)

DMX data IN: 1.5 m long cable with IP65 5-pin XLR connector (NEUTRIK NC5FXX-HD-D)
DMX data OUT: 1.5 m long cable with IP65 5-pin XLR connector (NEUTRIK NC5MXX-HD-D)
Power: 1.5 m long open ended cable (H07BB-F 3G1,5)
or
DMX data IN: open ended cable
DMX data OUT: open ended cable
Power: open ended cable (H07BB-F 3G1,5)

Rigging

Mounting points: 2 pairs of 1/4-turn locks
Mounting horizontally via two Omega brackets

Temperatures

Maximum ambient temperature: +45° C
Minimum ambient temperature: -30° C
Maximum housing temperature: 75° C

Minimum distances

Min. distance from flammable surfaces: 0.5 m
Min. distance of illuminated objects: 1 m

Total heat dissipation

Maximum: 1176 BTU/hr (calculated)

Ingress protection

IP65

Included items

1 x Omega adaptor CL-regular 2 pcs in box (P/N 10980033)
1 x power cable (IP65 rating)
1 x user manual

Weight

15.5 kg (34.17 lbs)

Dimensions (mm)

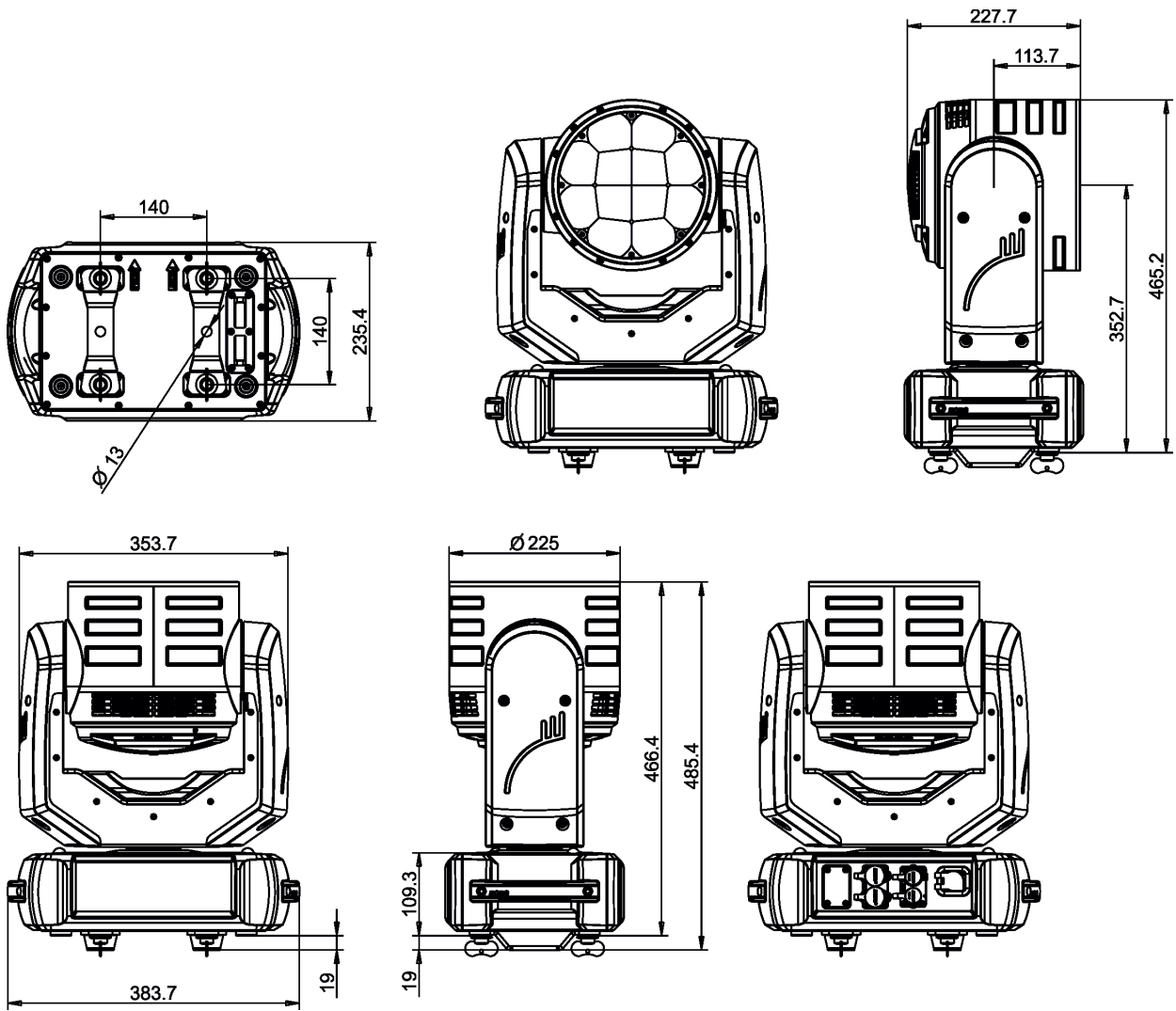

Optional accessories

- Doughty Trigger Clamp (P/N 17030386)
- Safety wire 35 kg (P/N 99011963)

18. ChangeLog

This section summarizes changes in the user manual.

Version of the manual	Date of issue	Description of changes
1.1	17/07/2023	POI version added
1.2	26/02/2024	POI version added (another variant)
1.3	04/12/2024	LEDs current calibration added

December 4, 2024

Copyright © 2023-2024 Robe Lighting - All rights reserved

All Specifications subject to change without notice

Made in CZECH REPUBLIC by ROBE LIGHTING s.r.o. Palackeho 416/20 CZ 75701 Valasske Mezirici



DMX protocol

Robin iBeam 350™ - DMX protocol						
Version: 1.0 Mode 1-Standard 16-bit, Mode 2 -Reduced 8-bit, Mode 3 - Cpulse mode						
Mode/channel			DMX Value	Function	Type of control	
1	2	3				
1	1	1		Pan (8 bit)		
			0 - 255	Pan movement by 540° or 450° (128=default)	proportional	
2	2	2		Pan Fine (16 bit)		
			0 - 255	Fine control of pan movement (0=default)	proportional	
3	3	3		Tilt (8 bit)		
			0 - 255	Tilt movement by 228° (128=default)	proportional	
4	4	4		Tilt fine (16 bit)		
			0 - 255	Fine control of tilt movement (0=default)	proportional	
5	5	5		Pan/Tilt speed , Pan/Tilt time		
			0	Standard mode (0=default)	step	
			1	Max. Speed Mode	step	
				Pan/Tilt speed mode		
			2 - 255	Speed from max. to min.	proportional	
				Pan/Tilt time mode		
			2 - 255	Time from 0.2 sec. to 25.5 sec.	proportional	
6	6	6		Power/Special functions		
			0-5	Reserved (0=default)		
				<i>To activate following functions, stop in DMX value for at least 3 s and shutter must be closed at least 3 sec. („Shutter,Strobe” channel 20/15/22 must be at range: 0-31 DMX). Corresponding menu items are temporarily overridden.</i>		
			6-7	Standby mode: On (fixture effects are deactivated, light output is closed)	step	
			8-9	Standby mode: Off	step	
			10-14	DMX input: Wired DMX *	step	
			15-19	DMX input: Wireless DMX *	step	
			20-24	Graphic display On	step	
			25-29	Graphic display Off	step	
			30-34	RGBW colour mixing mode	step	
			35-39	CMY colour mixing mode	step	
			40-44	Pan/Tilt speed mode	step	
			45-49	Pan/Tilt time mode	step	
			50-54	Blackout while pan/tilt moving	step	
			55-59	Disabled blackout while pan/tilt moving	step	
			60-64	Dimmer curve - square law	step	
			65-69	Dimmer curve - linear	step	
			70-74	Fans mode: Auto	step	
			75-79	Fans mode: High	step	
			80-84	White point 8000K On	step	
			85-89	White point 8000K Off	step	
			90-91	Pressure test: On (fixture does not respond to DMX during the test except values 92-93 (Pressure test: Off))	step	
			92-93	Pressure test: Off	step	
			94	Reserved		
			95-99	Pan 540°	step	
			100-104	Pan 450°	step	
			105-109	Quiet mode: Fans On at blackout	step	
			110-114	Quiet mode: Fans Off at blackout	step	

DMX protocol

Mode/channel			DMX Value	Function	Type of control
1	2	3			
			115-116	Parking position On	step
			117-118	Parking position Off	step
			119 -129	Reserved	
				<i>To activate following functions, stop in DMX value for at least 3 seconds. Corresponding menu items are temporarily overridden.</i>	
			130 - 139	Reserved	
			140 - 149	Pan/Tilt reset	step
			150 - 159	Zoom reset	step
			160 - 169	Reserved	step
				<i>Tungsten effect simulation for whites 2700K-4200K</i>	
			170-171	Tungsten effect simulation (750W) On	step
			172-173	Tungsten effect simulation (1000W) On	step
			174-175	Tungsten effect simulation (1200W) On	step
			176-177	Tungsten effect simulation (2000W) On	step
			178-179	Tungsten effect simulation (2500W) On	step
			180-181	Tungsten effect simulation Off	step
			182-199	Reserved	
			200 - 209	Total fixture reset	step
			210 - 218	Reserved	
				The following RoboSpot related commands are only applicable when the RoboSpot is connected:	
			219 - 220	RoboSpot enabled	step
			221 - 222	RoboSpot disabled - except handle faders and pan/tilt	step
			223 - 224	RoboSpot fully disabled	step
			225-239	Reserved	
			240	Disabled "Quiet mode"	step
			241 - 255	Quiet mode - fan noise control from min. to max.	proportional
*	*	7		LED frequency selection	
				Factory display menu setting: 600Hz	
				<i>Select PWM output frequency of LEDs (DMX mode 3 only). Selected PWM frequency can be fine adjusted in 127 steps up/down around selected PWM frequency on the channel below. Corresponding menu item (Frequency Setup) is temporarily overridden.</i>	
			0-4	PWM frequency from Display menu (fixture utilizes PWM frequency set in the display menu item Frequency Setup).	step
			5-9	300 Hz	step
			10-14	600 Hz (10=default)	step
			15-19	1200 Hz	step
			20-24	2400 Hz	step
			25-29	High	step
			30-255	Reserved (fixture utilizes PWM frequency set in the display menu item Frequency Setup).	
*	*	8		LED frequency fine adjusting	
				Factory display menu setting: 600Hz	
				<i>Select desired PWM output frequency of LEDs on the channel above (DMX mode 3 only).</i>	
			0-1	Selected LED Frequency	step
			2	LED Frequency (step -126)	step
			3	LED Frequency (step -125)	step
			4	LED Frequency (step -124)	step

DMX protocol

Mode/channel			DMX Value	Function	Type of control
1	2	3			
			:		
			125	LED Frequency (step -3)	step
			126	LED Frequency (step -2)	step
			127	LED Frequency (step -1)	step
			128	Selected LED Frequency (128=default)	step
			129	LED Frequency (step +1)	step
			130	LED Frequency (step +2)	step
			131	LED Frequency (step +3)	step
			:		
			252	LED Frequency (step +124)	step
			253	LED Frequency (step +125)	step
			254	LED Frequency (step +126)	step
			255	Selected LED Frequency	step
7	7	9		Virtual colour wheel	
			0	No function (0=default)	step
			1-2	Filter 4 (Medium Bastard Amber)	step
			3-4	Filter 25 (Sunset Red)	step
			5-6	Filter 19 (Fire)	step
			7-8	Filter 26 (Bright Red)	step
			9-10	Filter 58 (Lavender)	step
			11-12	Filter 68 (Sky Blue)	step
			13-14	Filter 36 (Medium Pink)	step
			15-16	Filter 89 (Moss Green)	step
			17-18	Filter 88 (Lime Green)	step
			19-20	Filter 90 (Dark Yellow Green)	step
			21-22	Filter 49 (Medium Purple)	step
			23-24	Filter 52 (Light Lavender)	step
			25-26	Filter 102 (Light Amber)	step
			27-28	Filter 103 (Straw)	step
			29-30	Filter 140 (Summer Blue)	step
			31-32	Filter 124 (Dark Green)	step
			33-34	Filter 106 (Primary Red)	step
			35-36	Filter 111 (Dark Pink)	step
			37-38	Filter 115 (Peacock Blue)	step
			39-40	Filter 126 (Mauve)	step
			41-42	Filter 117 (Steel Blue)	step
			43-44	Filter 118 (Light Blue)	step
			45-46	Filter 122 (Fern Green)	step
			47-48	Filter 182 (Light Red)	step
			49-50	Filter 121 (Filter Green)	step
			51-52	Filter 128 (Bright Pink)	step
			53-54	Filter 131 (Marine Blue)	step
			55-56	Filter 132 (Medium Blue)	step
			57-58	Filter 134 (Golden Amber)	step
			59-60	Filter 135 (Deep Golden Amber)	step
			61-62	Filter 136 (Pale Lavender)	step
			63-64	Filter 137 (Special Lavender)	step
			65-66	Filter 138 (Pale Green)	step
			67-68	Filter 798 (Chrysalis Pink)	step

DMX protocol

Mode/channel			DMX Value	Function	Type of control
1	2	3			
			69-70	Filter 141 (Bright Blue)	step
			71-72	Filter 147 (Apricot)	step
			73-74	Filter 148 (Bright Rose)	step
			75-76	Filter 152 (Pale Gold)	step
			77-78	Filter 154 (Pale Rose)	step
			79-80	Filter 157 (Pink)	step
			81-82	Filter 143 (Pale Navy Blue)	step
			83-84	Filter 162 (Bastard Amber)	step
			85-86	Filter 164 (Flame Red)	step
			87-88	Filter 165 (Daylight Blue)	step
			89-90	Filter 169 (Lilac Tint)	step
			91-92	Filter 170 (Deep Lavender)	step
			93-94	Filter 172 (Lagoon Blue)	step
			95-96	Filter 194 (Surprise Pink)	step
			97-98	Filter 180 (Dark Lavender)	step
			99-100	Filter 181 (Congo Blue)	step
			101-102	Filter 197 (Alice Blue)	step
			103-104	Filter 201 (Full C.T. Blue)	step
			105-106	Filter 202 (Half C.T. Blue)	step
			107-108	Filter 203 (Quarter C.T. Blue)	step
			109-110	Filter 204 (Full C.T. Orange)	step
			111-112	Filter 219 (Fluorescent Green)	step
			113-114	Filter 206 (Quarter C.T. Orange)	step
			115-116	Filter 247 (Filter Minus Green)	step
			117-118	Filter 248 (Half Minus Green)	step
			119-120	Filter 281 (Three Quarter C.T. Blue)	step
			121-122	Filter 285 (Three Quarter C.T. Orange)	step
			123-124	Filter 352 (Glacier Blue)	step
			125-126	Filter 353 (Lighter Blue)	step
			127-128	Filter 507 (Madge)	step
			129-130	Filter 778 (Millennium Gold)	step
			131-132	Filter 793 (Vanity Fair)	step
			133-235	Raw DMX	proportional
			236-245	Rainbow effect (with fade time) from slow-> fast	proportional
			246-255	Rainbow effect (without fade time) from slow-> fast	proportional
8	8	10		Red/Cyan (8 bit)**	
			0 - 255	Colour saturation control - coarse 0-100% (255=default)	proportional
9	*	11		Red/Cyan (16bit)**	
			0 - 255	Colour saturation control - fine (255=default)	proportional
10	9	12		Green/Magenta (8 bit)* *	
			0 - 255	Colour saturation control - coarse 0-100% (255=default)	proportional
11	*	13		Green/Magenta (16bit) **	
			0 - 255	Colour saturation control - fine (255=default)	proportional
12	10	14		Blue/Yellow (8 bit) **	
			0 - 255	Colour saturation control - coarse 0-100% (255=default)	proportional
13	*	15		Blue/ Yellow (16bit) **	
			0 - 255	Colour saturation control - fine (255=default)	proportional
14	11	16		White (8 bit)	
				<i>If RGBW mode is selected:</i>	

DMX protocol

Mode/channel			DMX Value	Function	Type of control
1	2	3			
			0-255	Colour saturation control - coarse 0-100% (255=default) <i>If CMY mode is selected:</i>	proportional
			0 - 255	No function	
15	*	17		White (16 bit)	
			0 - 255	Colour saturation control - fine (255=default)	proportional
16	12	18		CTO <i>If function "White Point 8000K" is On:</i>	
			0-255	Col. temperature correction from 8000K to 2700K -for whites only (0=8000K, 64=5600K, 128=4200K, 192=3200K, 255=2700K) To get colour temperatures stated above, RGBW channels have to be set at the same value e.g. 255DMX (0=default)	proportional
				<i>If function "White Point 8000K" is Off:</i>	
			0-255	No function	
17	13	19		Colour Mix control <i>Defines relation between colour channels</i> "Virtual" = Virtual Colours (Virtual Colour Wheel) "Colour mix" = Colour channels (RGBW/CMY)	
			0-9	Virtual colors ("Virtual" has priority)	step
			10-19	Maximum mode (highest values have priority)	step
			20-29	Minimum mode (lowest values have priority)	step
			30-39	Multiply mode (multiply Virtual and Colour Mix)	step
			40-49	Addition mode (Virtual + Colour mix) (45=default)	step
			50-59	Subtraction mode (Virtual – Colour mix)	step
			60-69	Inverted Subtraction mode (Virtual – Colour mix)	step
			70-128	Reserved	
			129	Virtual colors (virtual has priority)	step
			130-254	Crossfade (crossfade between Virtual and Colour mix)	proportional
			255	Colour channels ("Colour mix" has priority)	step
18	14	20		Zoom	
			0-255	Zoom from max. to min.beam angle (128=default)	proportional
19	*	21		Zoom - fine	
			0-255	Fine zooming (0=default)	proportional
20	15	22		Shutter/ strobe	
			0 - 31	Shutter closed	step
			32 - 63	Shutter open (32=default)	step
			64 - 95	Strobe-effect from slow to fast	proportional
			96 - 127	Shutter open	step
			128 - 143	Opening pulse in sequences from slow to fast	proportional
			144 - 159	Closing pulse in sequences from fast to slow	proportional
			160 - 191	Shutter open	step
			192 - 223	Random strobe-effect from slow to fast	proportional
			224 - 255	Shutter open	step
21	16	23		Dimmer intensity (8 bit)	
			0 - 255	Dimmer intensity from 0% to 100% (0=default)	proportional
22	*	24		Dimmer intensity - fine (16 bit)	
			0 - 255	Fine dimming (0=default)	proportional
* function is active only 10 seconds after switching the fixture on					
** Select RGB or CMY mixing mode on channel "Power/Special functions".					

DMX protocol

Mode/channel			DMX Value	Function	Type of control
1	2	3			
Copyright © 2023 Robe Lighting s.r.o. - All rights reserved					
All Specifications subject to change without notice					